

## Features

- 3.3V, 5V, 12V, 15V and adjustable output versions
- Adjustable version output voltage range,
- 1.23~37V±4% max over line and load conditions
- Guaranteed 2A output current
- Wide input voltage range
- Requires only 4 external components
- 150 KHz fixed frequency oscillator
- TTL shutdown capability, low power standby mode
- Uses readily available standard inductors
- Thermal shutdown and current limit protection

## Applications

- Simple high-efficiency step-down (buck) regulator
- Efficient pre-regulator for linear regulators
- On-card switching regulators
- Positive-to-negative converter (buck-boost)

## Package Pin Out

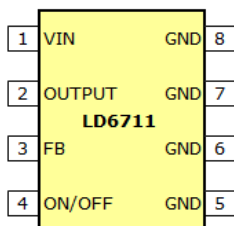

Pin Assignment of TO220, TO252, and TO263

Pin	Name
1	VIN
2	OUTPUT
3	GND
4	FB
5	ON/OFF

## General Description

The LD6711 series of regulators are monolithic integrated circuits that provide all the active functions for a step-down (buck) switching regulator, capable of driving 2A load with excellent line and load regulation. These devices are available in fixed output voltages of 3.3V, 5V, 12V, 15V and adjustable output versions. Requiring a minimum number of external components, these regulators are simple to use and include internal frequency compensation and a fixed-frequency oscillator.

The LD6711 series offers a high-efficiency replacement for popular three-terminal linear regulators. It substantially reduces the size of the heat sink, and in some cases no heat sink is required. A standard series of inductors optimized for use with the LD6711 are available from several different manufacturers. This feature greatly simplifies the design of switch-mode power supplies.

Other features include a guaranteed ± 4% tolerance on output voltage within specified input voltages and output load conditions, and ±10% on the oscillator frequency. External shutdown is included, featuring 50µA (typical) standby current. The output switch includes cycle-by-cycle current limiting, as well as thermal shutdown for full protection under fault conditions.

## Ordering Information

Part No.	Package	Packing Options	
		Tube (TU)	Tape & Reel (TR)
LD6711	SOP-8	LD6711S1-000-TU	LD6711S1-000-TR
	TO220-5L	LD6711T4-000-TU	LD6711T4-000-TR
	TO252-5L	LD6711T7-000-TU	LD6711T7-000-TR
	TO263-5L	LD6711T9-000-TU	LD6711T9-000-TR

- Package material default is "Green" package.

## Output Voltage Selection

Part No.	V <sub>OUT</sub>
LD6711S1-000-XX	Adjustable
LD6711S1-033-XX	3.3V
LD6711S1-050-XX	5.0V
LD6711S1-120-XX	12V
LD6711S1-150-XX	15V

## Product Marking

LD8888	◇ Line 1 – "LD" is a fixed character
SSSS...	8888: product name
●	◇ Line 2 – SSSS...: lot number

## Absolute Maximum Ratings

Parameter	Maximum	Unit
V <sub>IN</sub> supply voltage	45	V
Operating V <sub>IN</sub> supply voltage	5.1 to 40	V
ON/OFF pin voltage	-0.3 ≤ V ≤ V <sub>IN</sub>	V
FB pin voltage	-0.3 ≤ V ≤ V <sub>IN</sub>	V
OUTPUT pin to GND	-1	V
Operating current load	2.0	A
Junction temperature	150	°C
Operating temperature range	-40 to +125	°C
Storage temperature range	-65 to +150	°C
Power dissipation	Internal limited	

The values beyond the boundaries of absolute maximum rating may cause the damage to the device. Functional operation in this context is not implied. Continuous use of the device at the absolute rating level might influence device reliability. All voltages have their reference to device ground.

## Electrical Characteristics \*1

V<sub>IN</sub>=12V for 3.3V, 5V; V<sub>IN</sub>=25V for 12V, 15V and adjustable version, I<sub>LOAD</sub>=0.5A, T<sub>A</sub>=25°C unless specified

Parameter	Symbol	Condition	Min	Typ.	Max	Unit
<b>System Parameters</b>						
Output voltage range LD6711-033		V <sub>IN</sub> =12V, I <sub>LOAD</sub> =0.2A, V <sub>OUT</sub> =>3.3V	3.234	3.300	3.366	V
		5.1V ≤ V <sub>IN</sub> ≤ 40V, 0.2A ≤ I <sub>LOAD</sub> ≤ 2A, V <sub>OUT</sub> =>3.3V	3.168	3.300	3.432	
		5.1V ≤ V <sub>IN</sub> ≤ 40V, 0.2A ≤ I <sub>LOAD</sub> ≤ 2A, V <sub>OUT</sub> =>3.3V <sup>*7</sup>	3.135	3.300	3.465	
Output voltage range LD6711-050		V <sub>IN</sub> =12V, I <sub>LOAD</sub> =0.2A, V <sub>OUT</sub> =>5V	4.900	5.000	5.100	V
		7V ≤ V <sub>IN</sub> ≤ 40V, 0.2A ≤ I <sub>LOAD</sub> ≤ 2A, V <sub>OUT</sub> =>5V	4.800	5.000	5.200	
		7V ≤ V <sub>IN</sub> ≤ 40V, 0.2A ≤ I <sub>LOAD</sub> ≤ 2A, V <sub>OUT</sub> =>5V <sup>*7</sup>	4.750	5.000	5.250	
Output voltage range LD6711-120	V <sub>OUT</sub>	V <sub>IN</sub> =25V, I <sub>LOAD</sub> =0.2A, V <sub>OUT</sub> =>12V	11.76	12.00	12.24	V
		15V ≤ V <sub>IN</sub> ≤ 40V, 0.2A ≤ I <sub>LOAD</sub> ≤ 2A, V <sub>OUT</sub> =>12V	11.52	12.00	12.48	
		15V ≤ V <sub>IN</sub> ≤ 40V, 0.2A ≤ I <sub>LOAD</sub> ≤ 2A, V <sub>OUT</sub> =>12V <sup>*7</sup>	11.40	12.00	12.60	
Output voltage range LD6711-150		V <sub>IN</sub> =30V, I <sub>LOAD</sub> =0.2A, V <sub>OUT</sub> =>15V	14.70	15.00	15.30	V
		18V ≤ V <sub>IN</sub> ≤ 40V, 0.2A ≤ I <sub>LOAD</sub> ≤ 2A, V <sub>OUT</sub> =>15V	14.40	15.00	15.60	
		18V ≤ V <sub>IN</sub> ≤ 40V, 0.2A ≤ I <sub>LOAD</sub> ≤ 2A, V <sub>OUT</sub> =>15V <sup>*7</sup>	14.25	15.00	15.75	
Output voltage range LD6711-000		V <sub>IN</sub> =12V, I <sub>LOAD</sub> =0.2A, V <sub>OUT</sub> =>1.23V	1.217	1.230	1.243	V
		7V ≤ V <sub>IN</sub> ≤ 40V, 0.2A ≤ I <sub>LOAD</sub> ≤ 2A, V <sub>OUT</sub> =>1.23V	1.193	1.230	1.267	
		7V ≤ V <sub>IN</sub> ≤ 40V, 0.2A ≤ I <sub>LOAD</sub> ≤ 2A, V <sub>OUT</sub> =>1.23V <sup>*7</sup>	1.180	1.230	1.280	
Efficiency of LD6711-033	η	V <sub>IN</sub> =12V, I <sub>LOAD</sub> =2A, V <sub>OUT</sub> =>3.3V	-	75	-	%
Efficiency of LD6711-050		V <sub>IN</sub> =12V, I <sub>LOAD</sub> =2A, V <sub>OUT</sub> =>5V	-	77	-	
Efficiency of LD6711-120		V <sub>IN</sub> =25V, I <sub>LOAD</sub> =2A, V <sub>OUT</sub> =>12V	-	88	-	
Efficiency of LD6711-150		V <sub>IN</sub> =30V, I <sub>LOAD</sub> =2A, V <sub>OUT</sub> =>15V	-	88	-	
Efficiency of LD6711-000		V <sub>IN</sub> =12V, I <sub>LOAD</sub> =2A, V <sub>OUT</sub> =>1.23V	-	77	-	
<b>Device Parameters</b>						
Feedback bias current	I <sub>FB</sub>	V <sub>OUT</sub> =5V	-	50	100	nA
		V <sub>OUT</sub> =5V <sup>*7</sup>	-	-	500	
Oscillator frequency	F <sub>OSC</sub>	*6	130	150	170	KHz
		*6*7	120	-	180	
Saturation voltage	V <sub>SAT</sub>	V <sub>FB</sub> =0V, I <sub>LOAD</sub> =2A <sup>*2</sup>	-	1.4	1.8	V
		V <sub>FB</sub> =0V, I <sub>LOAD</sub> =2A <sup>*2*7</sup>	-	-	2.0	
Maximum duty cycle	DC <sub>MAX</sub>	V <sub>FB</sub> =0V (driver on) <sup>*3*7</sup>	93	98	-	%
Current limit	I <sub>CL</sub>	V <sub>FB</sub> =0V, peak current	2.5	3.0	4.0	A
		V <sub>FB</sub> =0V, peak current <sup>*7</sup>	2.3	-	4.2	
Output leakage current	I <sub>L</sub>	V <sub>OUT</sub> =-0.8V <sup>*4*5</sup>	-	7.5	30	mA
		V <sub>OUT</sub> =0V <sup>*4*5</sup>	-	-	2	
Quiescent current	I <sub>Q</sub>	*4	-	5	10	μA
Standby current	I <sub>STB</sub>	V <sub>ON/OFF</sub> =5V, V <sub>IN</sub> =40V	-	50	200	μA
		V <sub>ON/OFF</sub> =5V, V <sub>IN</sub> =40V <sup>*7</sup>	-	-	250	
<b>ON/OFF Control</b>						
ON/OFF pin input level	V <sub>IH</sub>	V <sub>OUT</sub> =0V	2.2	1.4	-	V
		V <sub>OUT</sub> =0V <sup>*7</sup>	2.4	-	-	
	V <sub>IL</sub>	V <sub>OUT</sub> =normal output	-	1.2	1.0	V
		V <sub>OUT</sub> =normal output <sup>*7</sup>	-	-	0.8	
ON/OFF pin input current	I <sub>IH</sub>	V <sub>ON/OFF</sub> =5V(off)	-	12	30	μA
	I <sub>IL</sub>	V <sub>ON/OFF</sub> =0V(on)	-	0	10	μA

**Notes:**

1. External components such as the catch diode, inductor, input and output capacitors can affect switching regulator system performance.
2. Output pin sourcing current. No diode, inductor or capacitor connected to output.
3. Feedback pin removed from output and connected to 0V.
4. Feedback pin removed from output and connected to +12V for the Adjustable, 3.3V, and 5V, versions, and +25V for the 12V and 15V versions, to force the output transistor OFF.
5. VIN =40V.
6. The oscillator frequency reduces to approximately 36 kHz in the event of an output short or an overload which causes the regulated output voltage to drop approximately 40% from the nominal output voltage. This self protections feature lowers the average power dissipation of the IC by lowering the minimum duty cycle from 5% down to approximately 2%.
7. This applied over full operation temperature range.

**Block Diagram**

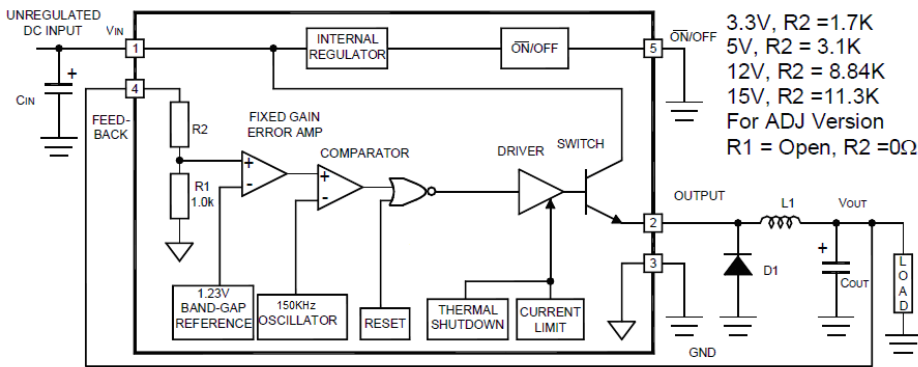

**Typical Application Circuit**

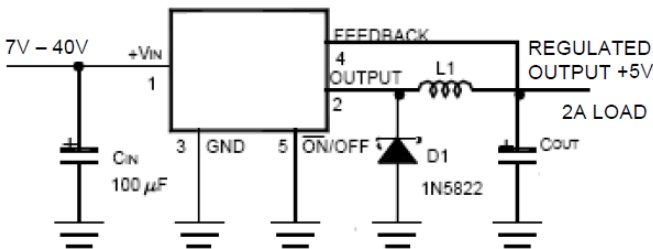

**Test Circuit and Layout Guidelines**

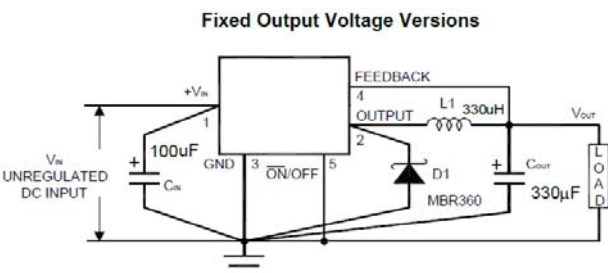

- C<sub>IN</sub> — 100µF, 75V, Aluminum Electrolytic  
 C<sub>OUT</sub> — 330µF, 25V, Aluminum Electrolytic  
 D1 — Schottky, MBR360  
 L<sub>1</sub> — 330µH, Pulse Eng. PE-92108  
 R<sub>1</sub> — 2k, 0.1%  
 R<sub>2</sub> — 6.12k, 0.1%

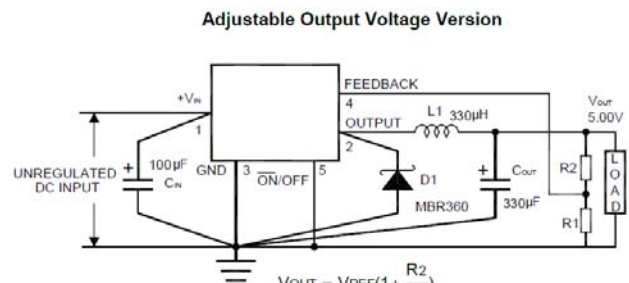

$$V_{OUT} = V_{REF} \left(1 + \frac{R_2}{R_1}\right)$$

$$R_2 = R_1 \left(\frac{V_{OUT}}{V_{REF}} - 1\right)$$

where V<sub>REF</sub> = 1.23V, R<sub>1</sub> between 1k and 5k

## Package Outline

SOP8:

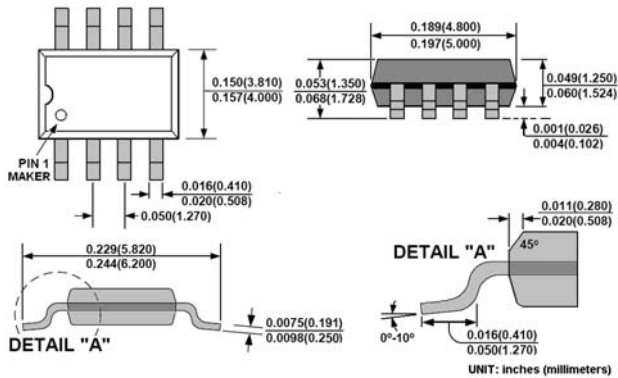

TO252-5L:

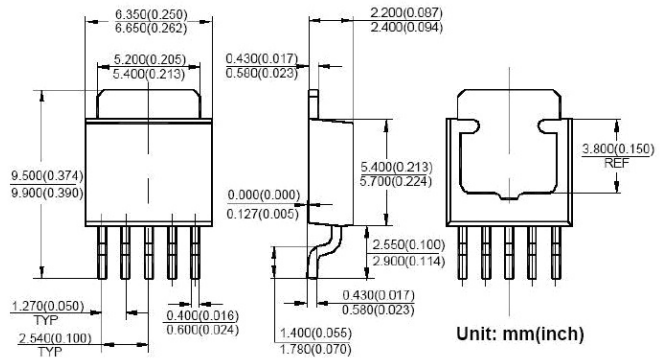

TO220-5L:

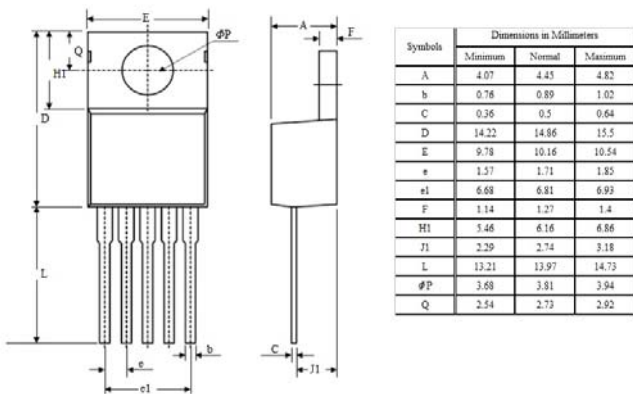

TO263-5L:

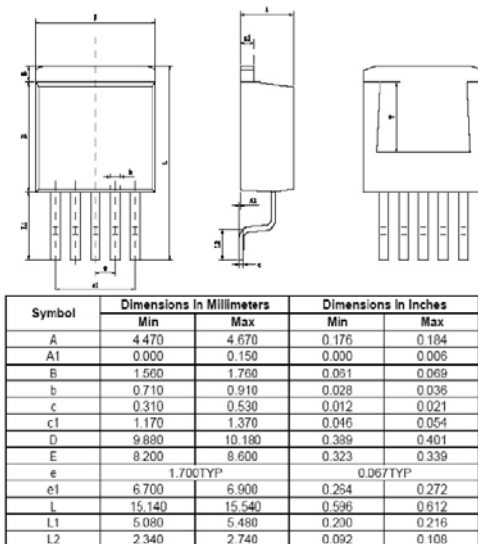

## LD Tech Corporation

Tel: +886-3-567-8806

Fax: +886-3-567-8706

E-mail: [sales@ldtech.com.tw](mailto:sales@ldtech.com.tw)

Website: [www.ldtech.com.tw](http://www.ldtech.com.tw)