

Features

- 3.3V, 5V, 12V, 15V and adjustable output versions
- Adjustable version output voltage range,
- 1.23~57V±4% max over line and load conditions
- Guaranteed 2A output current
- Wide input voltage range, 60V
- Requires only 4 external components
- 52 kHz fixed frequency oscillator
- TTL shutdown capability, low power standby mode
- High efficiency
- Uses readily available standard inductors
- Thermal shutdown and current limit protection

Applications

- Simple high-efficiency step-down (buck) regulator
- Efficient pre-regulator for linear regulators
- On-card switching regulators
- Positive-to-negative converter (buck-boost)

Package Pin Out

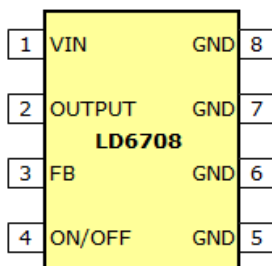
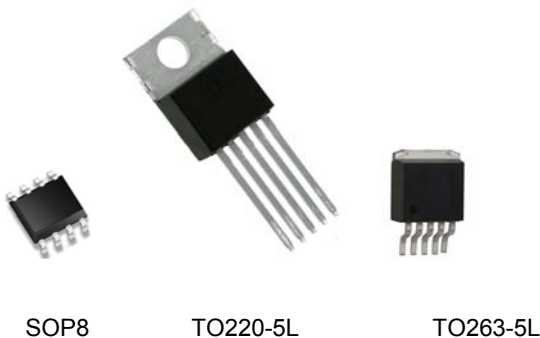

Pin Assignment of TO220-5L and TO263-5L

Pin	Name
1	VIN
2	OUTPUT
3	GND
4	FB
5	ON/OFF

General Description

The LD6708 series of regulators are monolithic integrated circuits that provide all the active functions for a step-down (buck) switching regulator, capable of driving 2A load with excellent line and load regulation. These devices are available in fixed output voltages of 3.3V, 5V, 12V, 15V and adjustable output versions. Requiring a minimum number of external components, these regulators are simple to use and include internal frequency compensation and a fixed-frequency oscillator.

The LD6708 series offers a high-efficiency replacement for popular three-terminal linear regulators. It substantially reduces the size of the heat sink, and in some cases no heat sink is required. A standard series of inductors optimized for use with the LD6708 are available from several different manufacturers. This feature greatly simplifies the design of switch-mode power supplies.

Other features include a guaranteed ± 4% tolerance on output voltage within specified input voltages and output load conditions, and ±10% on the oscillator frequency. External shutdown is included, featuring 50µA (typical) standby current. The output switch includes cycle-by-cycle current limiting, as well as thermal shutdown for full protection under fault conditions.

Ordering Information

Part No.	Package	Packing Options	
		Tube (TU)	Tape & Reel (TR)
LD6708	SOP-8	LD6708S1-000-TU	LD6708S1-000-TR
	TO220-5L	LD6708T4-000-TU	LD6708T4-000-TR
	TO263-5L	LD6708T9-000-TU	LD6708T9-000-TR

- Package material default is "Green" package.

Output Voltage Selection

Part No.	V _{OUT}
LD6708S1-000-XX	Adjustable
LD6708S1-033-XX	3.3V
LD6708S1-050-XX	5.0V
LD6708S1-120-XX	12V
LD6708S1-150-XX	15V

Product Marking

LD8888	◇ Line 1 – "LD" is a fixed character
SSSSS...	8888: product name
●	◇ Line 2 – SSSSS...: lot number

Absolute Maximum Ratings*1

Parameter	Maximum	Unit
V _{IN} supply voltage	60	V
Operating V _{IN} supply voltage	4.5 to 40	V
ON/OFF pin voltage	-0.3 ≤ V ≤ V _{IN}	V
FB pin voltage	-0.3 ≤ V ≤ V _{IN}	V
OUTPUT pin to GND	-0.75	V
Operating current load	2.0	A
Junction temperature	150	°C
Operating temperature range	-40 to +125	°C
Storage temperature range	-65 to +150	°C
Power dissipation	Internal limited	

The values beyond the boundaries of absolute maximum rating may cause the damage to the device. Functional operation in this context is not implied. Continuous use of the device at the absolute rating level might influence device reliability. All voltages have their reference to device ground.

Electrical Characteristics

V_{IN}=12V for 3.3V, 5V, 12V, 15V and adjustable version, I_{LOAD}=0.5A, T_A=25°C unless specified

Parameter	Symbol	Condition	Min	Typ.*2	Max	Unit
System Parameters*3						
Output voltage range LD6708-033	V _{OUT}	V _{IN} =12V, I _{LOAD} =0.5A, V _{OUT} =>3.3V	3.234	3.300	3.366	V
		5.5V ≤ V _{IN} ≤ 60V, 0.5A ≤ I _{LOAD} ≤ 2A, V _{OUT} =>3.3V	3.168	3.300	3.450	
		5.5V ≤ V _{IN} ≤ 60V, 0.5A ≤ I _{LOAD} ≤ 2A, V _{OUT} =>3.3V*9	3.135	3.300	3.482	
Output voltage range LD6708-050	V _{OUT}	V _{IN} =12V, I _{LOAD} =0.5A, V _{OUT} =>5V	4.900	5.000	5.100	V
		7.5V ≤ V _{IN} ≤ 60V, 0.5A ≤ I _{LOAD} ≤ 2A, V _{OUT} =>5V	4.800	5.000	5.225	
		7.5V ≤ V _{IN} ≤ 60V, 0.5A ≤ I _{LOAD} ≤ 2A, V _{OUT} =>5V*9	4.750	5.000	5.275	
Output voltage range LD6708-120	V _{OUT}	V _{IN} =25V, I _{LOAD} =0.5A, V _{OUT} =>12V	11.76	12.00	12.24	V
		14.5V ≤ V _{IN} ≤ 60V, 0.5A ≤ I _{LOAD} ≤ 2A, V _{OUT} =>12V	11.52	12.00	12.54	
		14.5V ≤ V _{IN} ≤ 60V, 0.5A ≤ I _{LOAD} ≤ 2A, V _{OUT} =>12V*9	11.40	12.00	12.66	
Output voltage range LD6708-150	V _{OUT}	V _{IN} =25V, I _{LOAD} =0.5A, V _{OUT} =>12V	14.70	15.00	15.30	V
		17.5V ≤ V _{IN} ≤ 60V, 0.5A ≤ I _{LOAD} ≤ 2A, V _{OUT} =>15V	14.40	15.00	15.68	
		17.5V ≤ V _{IN} ≤ 60V, 0.5A ≤ I _{LOAD} ≤ 2A, V _{OUT} =>15V*9	14.25	15.00	15.83	
Output voltage range LD6708-000	V _{OUT}	V _{IN} =12V, I _{LOAD} =0.5A, V _{OUT} =>1.23V	1.217	1.230	1.243	V
		7.5V ≤ V _{IN} ≤ 60V, 0.5A ≤ I _{LOAD} ≤ 2A, V _{OUT} =>1.23V	1.193	1.230	1.273	
		7.5V ≤ V _{IN} ≤ 60V, 0.5A ≤ I _{LOAD} ≤ 2A, V _{OUT} =>1.23V*9	1.180	1.230	1.286	
Efficiency of LD6708-033	η	V _{IN} =12V, I _{LOAD} =2A, V _{OUT} =>3.3V	-	75	-	%
Efficiency of LD6708-050		V _{IN} =12V, I _{LOAD} =2A, V _{OUT} =>5V	-	77	-	
Efficiency of LD6708-120		V _{IN} =12V, I _{LOAD} =2A, V _{OUT} =>12V	-	88	-	
Efficiency of LD6708-150		V _{IN} =18V, I _{LOAD} =2A, V _{OUT} =>15V	-	88	-	
Efficiency of LD6708-000		V _{IN} =12V, I _{LOAD} =2A, V _{OUT} =>1.23V	-	77	-	
Device Parameters						
Feedback bias current	I _{FB}	V _{OUT} =5V V _{OUT} =5V*9	-	50	100	nA
Oscillator frequency	F _{OSC}	*8	47	52	58	KHz
		*8*9	42	-	63	
Saturation voltage	V _{SAT}	V _{FB} =0V, I _{LOAD} =2A*4	-	1.2	1.35	V
		V _{FB} =0V, I _{LOAD} =2A*4*9	-	-	1.45	
Maximum duty cycle	DC _{MAX}	V _{FB} =0V (driver on)*5*9	93	98	-	%
Current limit	I _{CL}	V _{FB} =0V, peak current	2.5	3.4	4.6	A
		V _{FB} =0V, peak current*9	2.3	-	4.9	
Output leakage current	I _L	V _{OUT} =-0.75V*6*7	-	7.5	30	mA
		V _{OUT} =0V*6*7	-	-	2	
Quiescent current	I _Q	*6	-	5	10	μA
Standby current	I _{STB}	V _{ON/OFF} =5V, V _{IN} =60V	-	50	200	μA
		V _{ON/OFF} =5V, V _{IN} =60V*9	-	-	250	
ON/OFF Control						
ON/OFF pin input level	V _{IH}	V _{OUT} =0V	1.4	2.2	2.4	V
	V _{IL}	V _{OUT} =normal output	0.8	1.0	1.2	V
ON/OFF pin input current	I _{IH}	V _{ON/OFF} =5V(off)	-	0	30	μA
	I _{IL}	V _{ON/OFF} =0V(on)	-	0	10	μA

Notes:

1. Absolute Maximum Ratings indicate limits beyond which damage to the device may occur. Operating Ratings indicate conditions for which the device is intended to be functional, but do not guarantee specific performance limits. For guaranteed specifications and test conditions, see the Electrical Characteristics.
2. All limits guaranteed at room temperature (standard type face) and at temperature extremes (bold type face).
3. External components such as the catch diode, inductor, input and output capacitors can affect switching regulator system performance. When the 2HV76K/3HV76K is used as shown in the *Figure 2* test circuit, system performance will be as shown in system parameters section of Electrical Characteristics.
4. Output pin sourcing current. No diode, inductor or capacitor connected to output.
5. Feedback pin removed from output and connected to 0V.
6. Feedback pin removed from output and connected to +12V for the Adjustable, 3.3V, and 5V, versions, and +25V for the 12V and 15V versions, to force the output transistor OFF.
7. $V_{IN} = 60V$.
8. The oscillator frequency reduces to approximately 11 kHz in the event of an output short or an overload which causes the regulated output voltage to drop approximately 40% from the nominal output voltage. This self protections feature lowers the average power dissipation of the IC by lowering the minimum duty cycle from 5% down to approximately 2%.
9. This applied over full operation temperature range.

Block Diagram

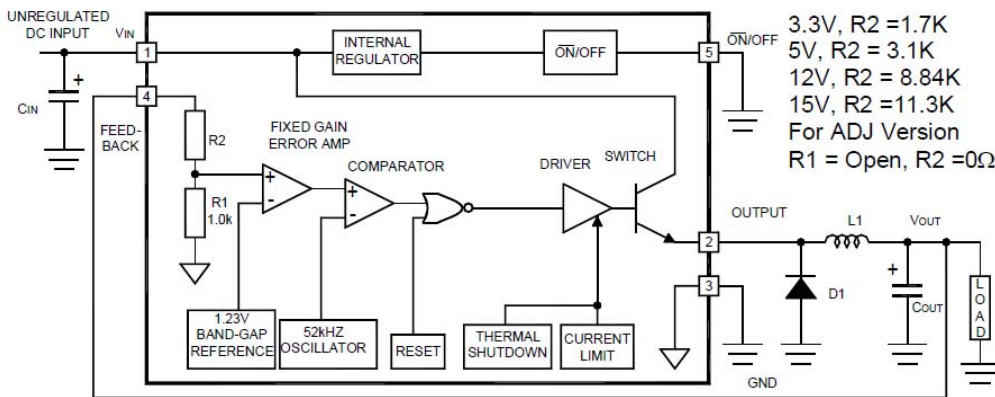

Typical Application Circuit

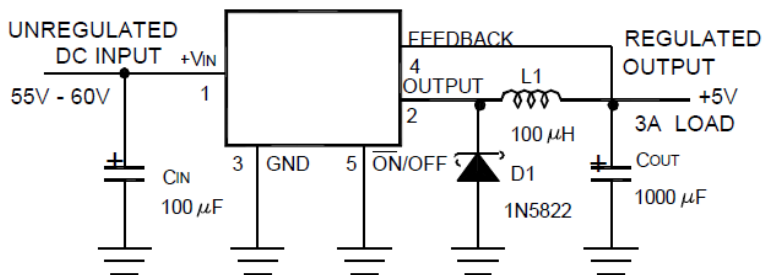

Package Outline

SOP8:

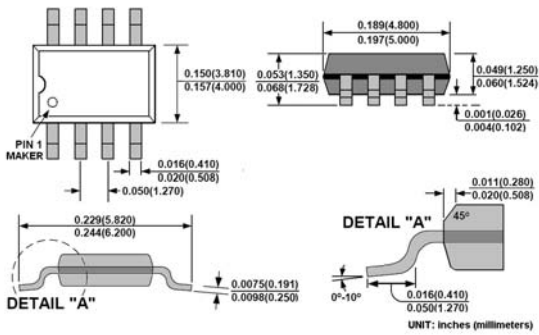

TO220-5:

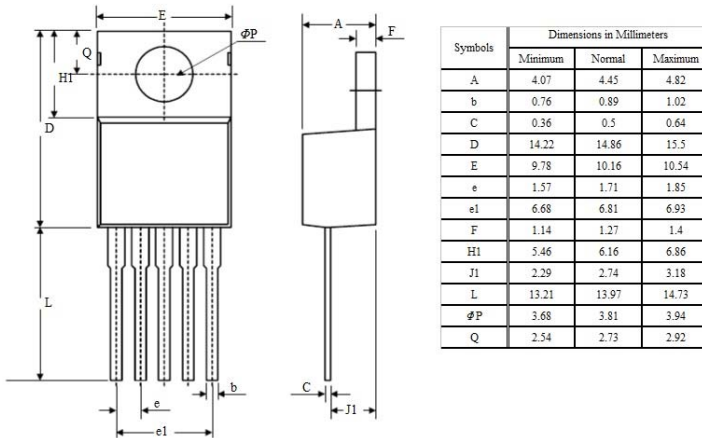

TO263-5:

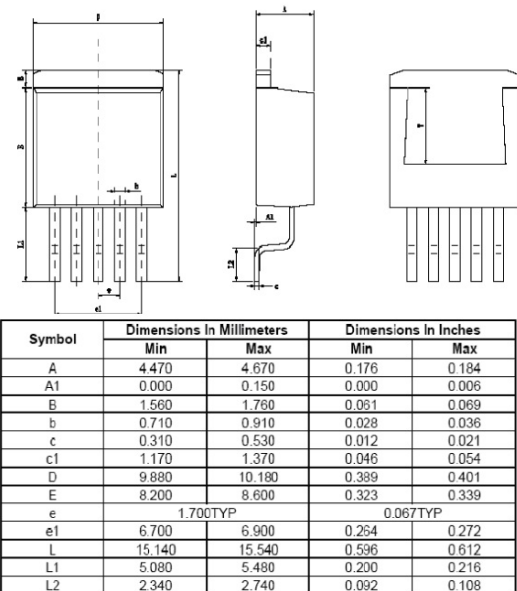

LD Tech Corporation

Tel: +886-3-567-8806

Fax: +886-3-567-8706

E-mail: sales@ldtech.com.tw

Website: www.ldtech.com.tw