

Features

- Output voltage range, 1.23V to 37V
- $\pm 4\%$ max over the line and load conditions
- Guaranteed 2A output current
- Wide input voltage range, up to 40V
- 340kHz fixed frequency oscillator
- TTL shutdown, low power standby mode
- High efficiency
- Thermal shutdown and current limit protection
- Low input offset voltage, offset current of Op Amp
- Internal frequency compensation of Op Amp

Applications

- DC/DC or AC/DC LED driver applications
- Simple Chargers

Package Pin Out

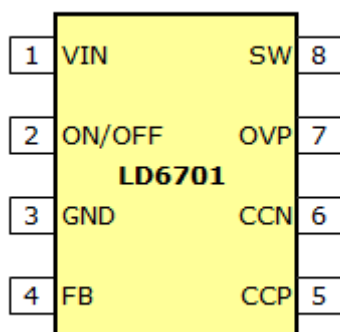

General Description

Many chargers use a well-known device – Type 2576 - in conjunction with operational amplifiers. This allows one to introduce an additional adjustment for the Over Current Protection (OCP) and Over Voltage Protection (OVP). In this case the OCP and OVP values can be changed with the help of external resistors. LD6701 includes both devices – the 2576 and Op Amp, thereby reducing the size of a charger and the cost of charger applications.

LD6701 provides all active functions for a step-down (buck) switching regulator and is capable of driving 2A load with an excellent line and load regulation. It includes internal frequency compensation components and a fixed-frequency oscillator. Among other features are a guaranteed $\pm 4\%$ tolerance for an output voltage within the specified input voltage and output load conditions, and a $\pm 10\%$ tolerance for an oscillator frequency. An external shutdown is included, featuring 120 μ A (typical) standby current.

Ordering Information

Part No.	Package	Packing Options	
		Tube (TU)	Tape & Reel (TR)
LD6701	SOP-8	LD6701S1-000-TU	LD6701S1-000-TR

- Package material default is "Green" package.

Output Voltage Selection

Part No.	V _{OUT}
LD6701S1-000-XX	Adjustable
LD6701S1-033-XX	3.3V
LD6701S1-050-XX	5.0V
LD6701S1-120-XX	12V
LD6701S1-150-XX	15V

Product Marking

LD8888 SSSS...	◇ Line 1 – "LD" is a fixed character 8888: product name
●	◇ Line 2 – SSSS...: lot number

Absolute Maximum Ratings

Parameter	Maximum	Unit
V _{IN} supply voltage	45	V
Operating V _{IN} supply voltage	5 to 40	V
FB, ON/OFF pin voltage	-0.3 to V _{IN}	V
SW output pin voltage	-0.8 to V _{IN} +0.3	V
Input differential voltage V _{IDR}	45	V
Input common mode voltage V _{ICR}	-0.3 to 45	V
Junction temperature	150	°C
Operating temperature range	-40 to +125	°C
Storage temperature range	-65 to +150	°C
Power dissipation	Internal limited	

The values beyond the boundaries of absolute maximum rating may cause the damage to the device. Functional operation in this context is not implied. Continuous use of the device at the absolute rating level might influence device reliability. All voltages have their reference to device ground.

Electrical Characteristics

V_{IN}=12V, T_A=25°C unless specified, otherwise minimum and maximum values are guaranteed by production testing requirements.

Parameter	Symbol	Condition	Min	Typ.	Max	Unit
System Parameters						
Output voltage range LD6701-000	V _{OUT}	V _{IN} =12V, I _{LOAD} =0.5A, V _{OUT} >=5V	1.215	1.230	1.245	V
		7V ≤ V _{IN} ≤ 40V, 0.5A ≤ I _{LOAD} ≤ 2A, V _{OUT} >=5V	1.193	1.230	1.267	V
		7V ≤ V _{IN} ≤ 40V, 0.5A ≤ I _{LOAD} ≤ 2A, V _{OUT} >=5V ^{*10}	1.180	–	1.280	
Tolerance of output voltage	TOL	10V ≤ V _{IN} ≤ 30V, 0.5A ≤ I _{LOAD} ≤ 2A	-2	–	+2	%
Efficiency	η	V _{IN} =12V, I _{LOAD} =2A, V _{OUT} >=5V	–	77	–	%
Output voltage range LD6701-050	V _{OUT}	V _{IN} =12V, I _{LOAD} =0.5A	4.90	5.00	5.10	V
		7V ≤ V _{IN} ≤ 40V, 0.5A ≤ I _{LOAD} ≤ 2A, V _{OUT} >=5V	4.80	–	5.20	V
		7V ≤ V _{IN} ≤ 40V, 0.5A ≤ I _{LOAD} ≤ 2A, V _{OUT} >=5V ^{*10}	4.75	–	5.25	V
Device Parameters						
FB bias current	I _{FB}	V _{OUT} =5V, V _{FB} =1.3V, V _{CCN} - V _{CCP} =0.1V	–	50	100	nA
		V _{OUT} =5V, V _{FB} =1.3V, V _{CCN} - V _{CCP} =0.1V ^{*10}	–	–	500	
Oscillator frequency	F _{OSC}	*6	47	52	57	KHz
		*6*10	42	–	62	
Saturation voltage	V _{SAT}	*2	–	1.1	1.25	V
		*2*10	–	–	1.35	
Maximum duty cycle	DC	*3	93	98	–	%
Current limit	I _{CL}	*2*6	2.5	3.4	4.6	A
		*2*6*10	2.3	–	5.2	
Output leakage current	I _{OL}	V _{OUT} =0V ^{*4*5}	–	0.4	2	mA
		V _{OUT} =-0.8V ^{*4*5}	–	10	30	
Operational Amplifier, CC-AMP						
Input offset voltage	V _{IO}	5V ≤ V _{IN} ≤ 40V, V _{IC} =0V, V _{FB} =1.5V	–	4	11	mV
Average temperature coefficient of input offset voltage	ΔV _{IO}	5V ≤ V _{IN} ≤ 40V, V _{IC} =0V, V _{FB} =1.5V	–	10	15	μV/°C
		5V ≤ V _{IN} ≤ 40V, V _{IC} =0V, V _{FB} =1.5V ^{*10}	–	10	–	
Input offset current	I _{IO}	V _{IC} =0V	–	8	100	nA
		V _{IC} =0V ^{*10}	–	–	300	
Avg. temp. coeff. of input offset current	ΔI _{IO}		–	20	–	pA/°C
Input bias current	I _{IB}	V _{IC} =0V	–	-30	-500	nA
		V _{IC} =0V ^{*10}	–	–	-800	
Common mode input voltage range	V _{ICR}	5V ≤ V _{IN} ≤ 40V	–	0~V _{IN} -5	–	V
		5V ≤ V _{IN} ≤ 40V ^{*10}	–	0~V _{IN} -2	–	
High level output voltage	V _{FBH}	R _L ≥ 15KΩ, V _{IN} =40V ^{*8}	37.5	38	–	V
		R _L ≥ 15KΩ, V _{IN} =40V ^{*8*10}	37	–	–	
Low level output voltage	V _{FBL}	R _L ≥ 10KΩ	–	5	20	mV
		R _L ≥ 10KΩ ^{*10}	–	–	30	
Common mode rejection ratio	CMRR	V _{IC} =0V to V _{IN} -1.5V	60	80	–	dB
Power supply rejection ratio	PSRR		60	90	–	dB
Output current	I _O	V _{IN} =12V, V _{IO} =1V, V _{FB} >=1.5V	–	-40	-20	mA
		V _{IN} =12V, V _{IO} =1V, V _{FB} >=1.5V ^{*10}	–	–	-10	
Short circuit output current to GND	I _{SC}	V _{IO} =1V, V _{FB} >=0V	-60	-40	–	mA

ON/OFF Control						
ON/OFF pin logic input level	V_{IH}	$V_{OUT}=0V$	2.2	1.4	–	V
		$V_{OUT}=0V^{*10}$	2.4	–	–	
	V_{IL}	$V_{OUT}=\text{normal output}$	–	1.2	1.0	V
		$V_{OUT}=\text{normal output}^{*10}$	–	–	0.8	
ON/OFF pin input current	I_{IH}	ON/OFF pin=5V(off)	–	12	30	μA
		ON/OFF pin=0V(on)	–	0	10	
OVP pin high voltage threshold	OVP_H	*7	1.15	1.22	1.31	V
		*7*10	1.11	–	1.35	
OVP pin low voltage threshold	OVP_L	*7	–	0.74	–	V
OVP pin input current	I_{OVP}	$V_{OVP}=1.3V$	–	50	100	nA
		$V_{OVP}=1.3V^{*10}$	–	–	500	
Common Parameters						
Quiescent current	I_Q	no load Op Amp ⁴	–	5.5	11	mA
Standby quiescent current	I_{STBY}	ON/OFF pin=5V(off), no load Op Amp	–	120	330	μA

Notes: 1. External components such as a catch diode, an inductor, input and output capacitors can affect switching regulator system performance. 2. Output Pin sourcing current. No diode, inductor or capacitors are connected to output. 3. FB Pin removed from the output and connected to 0V. 4. FB pin removed from the output and connected to +12V to force the output transistor off. 5. $V_{IN}=40V$. 6. The oscillator frequency reduces to approximately 85 kHz in the event of an output shorting or an overload, which causes the regulated output voltage to drop approximately 40% from the nominal output voltage. This self-protection feature lowers the average power dissipation of the IC by lowering the minimum duty cycle from 5% down to approximately 2%. 7. When the voltage of the OVP pin is higher than OVP_H , the circuit is Off. When the voltage of the OVP pin decreases and is less than OVP_L , the circuit is On. 8. RL between FB and Gnd. 9. Good use of the PC board's ground plane can help considerably to dissipate heat. The exposed pad on the bottom of the IC package must be soldered to a ground plane and that plane should extend out from beneath the IC to help dissipate the heat. The exposed pad is internally connected to the IC substrate. 10. this denotes the specifications, which apply over the full operating temperature range.

Block Diagram

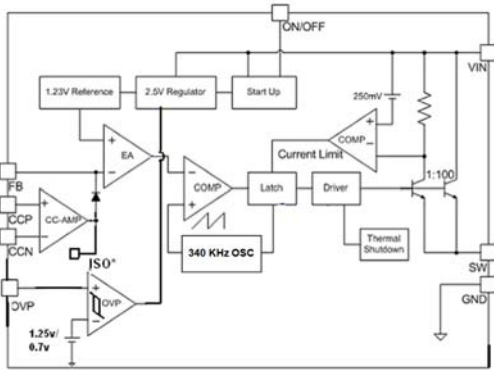

Typical Application Circuit

Version 1:

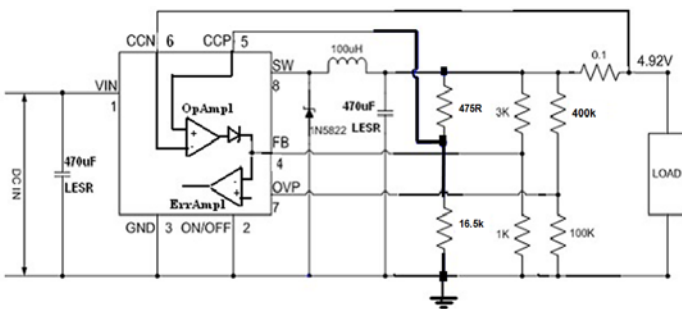

Version 2:

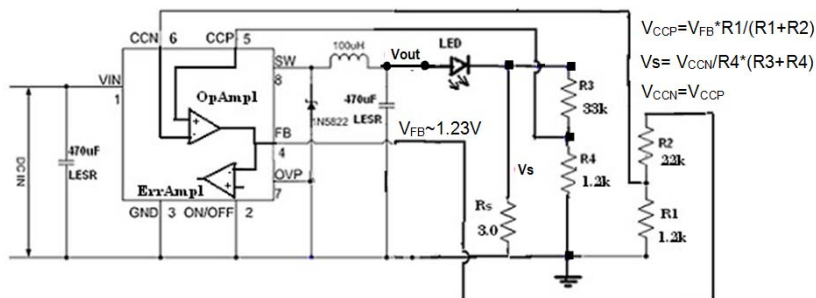

Package Outline

SOP8:

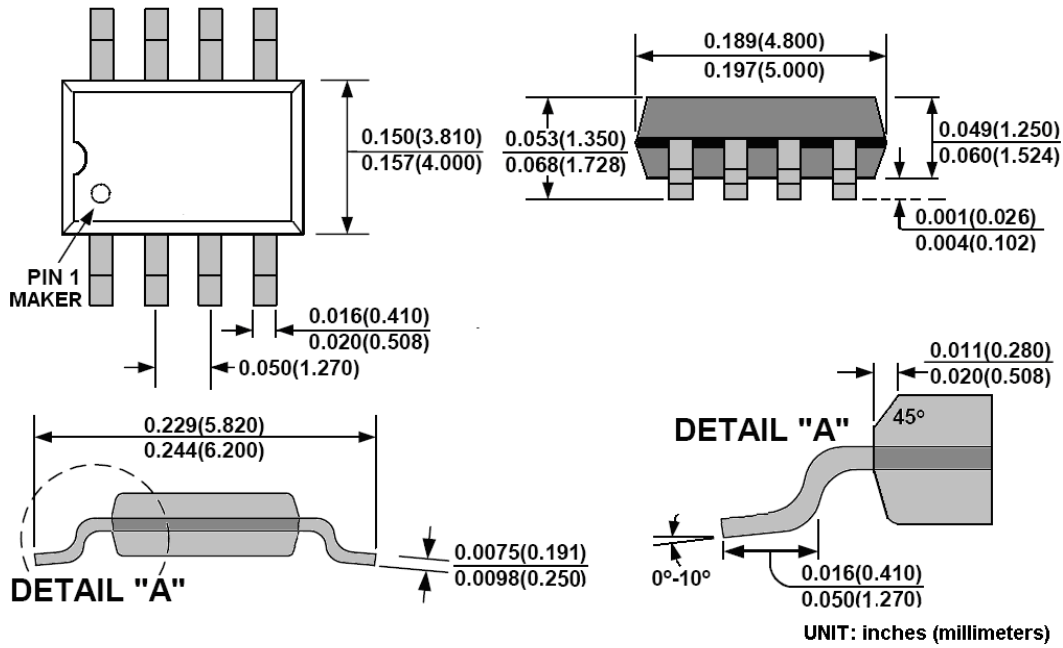

LD Tech Corporation

Tel: +886-3-567-8806
 Fax: +886-3-567-8706
 E-mail: sales@ldtech.com.tw
 Website: www.ldtech.com.tw