

Features

- Wide range of supply voltages
- Low supply current drain independent of supply voltage
- Low input biasing current
- Low input offset current
- Low input offset voltage
- Input common-mode voltage range includes GND
- Differential input voltage range equal to the power supply voltage
- Low output saturation voltage
- Output voltage compatible with TTL, MOS and CMOS logic

Applications

- Transducer amplifiers
- DC gain blocks
- Op amp circuits.

Package Pin Out

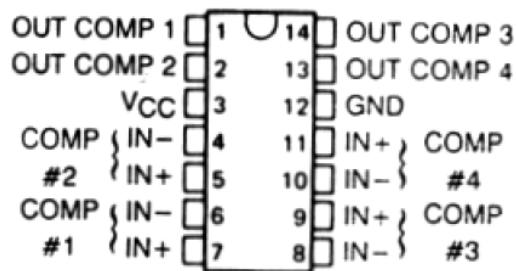

General Description

The LD6512 consists of four independent voltage comparators. These were designed specifically to operate from a single power supply over a wide range of voltages.

Operation from split power supplies is also possible and the low power supply current drain is independent of the magnitude of the power supply voltage.

The outputs can be connected to other open-collector outputs to achieve wired-AND relationships..

Ordering Information

		Packing Options	
Part No.	Package	Tube (TU)	Tape & Reel (TR)
LD6512	SOP-14	LD6512S2-TU	LD6512S2-TR

- Package material default is "Green" package.

Product Marking

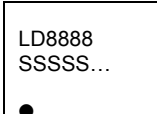
	<ul style="list-style-type: none"> ◇ Line 1 – "LD" is a fixed character 8888: product name ◇ Line 2 – SSSSS...: lot number
---	--

Absolute Maximum Ratings

Parameter	Maximum	Unit
V _{IN} to GND	-15 to +15	V
V _{CC} to GND	±15	V
Operating Junction Temperature	-40 to +125	°C
Storage Temperature	-65 to +150	°C

The values beyond the boundaries of absolute maximum rating may cause the damage to the device. Functional operation in this context is not implied. Continuous use of the device at the absolute rating level might influence device reliability. All voltages have their reference to device ground.

Electrical Characteristics

V_{CC}=5V, T_A=25°C unless specified, otherwise minimum and maximum values are guaranteed by production testing requirements.

Parameter	Symbol	Condition ^{*1}	Min	Typ.	Max	Unit	
Input							
Input offset voltage	V _{IO}	V _{CC} =5V to 30V, V _{IC} =V _{ICRmin} , V _O =1.4V	25°C	–	2	5	mV
			-40~ +125°C	–	–	9	
Input offset current	I _{IO}	V _O =1.4V	25°C	–	5	50	nA
			-40~ +125°C	–	–	150	
Input bias current	I _{IB}	V _O =1.4V	25°C	–	-25	-250	nA
			-40~ +125°C	–	–	-400	
Common-mode input voltage range ^{*2}	V _{ICR}	V _{CC} = 5V to MAX	25°C	0 to V _{CC} -1.5	–	–	V
			-40~ +125°C	0 to V _{CC} -2	–	–	
Large-signal differential voltage amplification	A _{VD}	V _{CC} =15V, V _O =1.4V to 11.4V, R _L ≥ 15KΩ to V _{CC}	25°C	50	200	–	V/mV
Output							
High-level output current	I _{OH}	V _{OH} =5V, V _{ID} =1V	25°C	–	0.1	50	nA
		V _{OH} =30V, V _{ID} =1V	-40~ +125°C	–	–	1	μA
Low-level output voltage	V _{OL}	I _{OL} =4mA, V _{ID} = -1V	25°C	–	150	400	mV
			-40~ +125°C	–	–	700	
Low-level output current	I _{OL}	V _{OL} =1.5V, V _{ID} = -1V	25°C	6	–	–	mA
Supply current (four amplifiers)	I _{CC}	V _{CC} =5V, R _L =∞	25°C	–	0.8	2	mA
		V _{CC} =30V, R _L =∞	-40~ +125°C	–	–	2.5	

Switching Characteristics

V_{IN}=5V, T_A=25°C unless specified, otherwise minimum and maximum values are guaranteed by production testing requirements.

Parameter	Symbol	Condition	Min	Typ.	Max	Unit
Response time	T	*3*4	–	1.5	–	μS
		*3*5	–	0.3	–	

Notes:

1. Full range (MIN to MAX), for the LD6512 is - 40°C to 125°C. All characteristics are measured with zero common-mode input voltage unless otherwise specified.
2. The voltage at either input or common-mode should not be allowed to go negative by more than 0.3V. The upper end of the common-mode voltage range is V_{CC} -1.5V, but either or both inputs can go to 30V without damage.
3. The response time specified is the interval between the input step function and the instant, when the output crosses 1.4V.
4. R_L connected to 5V through 5.1KΩ, C_L=15pF, 100-mV input step with 5-mV overdrive
5. R_L connected to 5V through 5.1KΩ, C_L=15pF, TTL-level input step

Package Outline
SOP-14:

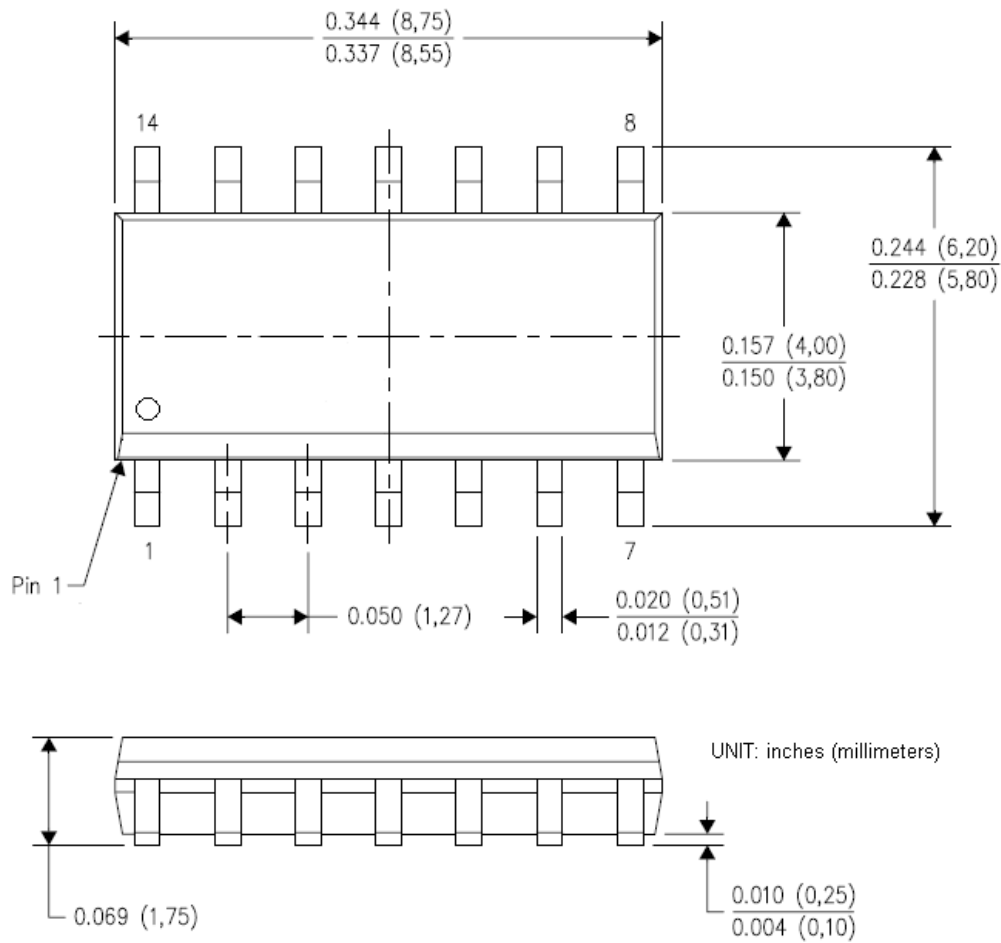

LD Tech Corporation

Tel: +886-3-567-8806
 Fax: +886-3-567-8706
 E-mail: sales@ldtech.com.tw
 Website: www.ldtech.com.tw