

Features

- High current capability: 1A
- Low-dropout voltage: 400mV
- Low ground current
- Accurate 1% guaranteed tolerance
- Extremely fast transient response
- Reverse-battery protection
- Zero-current shutdown mode (5-pin versions)
- Also characterized for smaller loads with industry-leading performance specifications
- Fixed voltage and adjustable versions

Applications

- Battery powered equipment
- High-efficiency “green” computer systems
- Automotive electronics
- High-efficiency linear power supplies
- High-efficiency post-regulator for switching supply

Package Pin Out

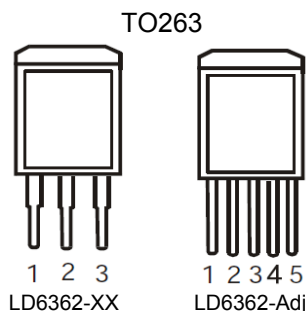
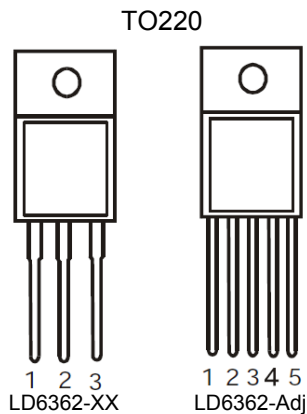

General Description

The LD6362 are high current, high accuracy, low-dropout voltage regulators. Using process with a PNP pass element, these regulators feature 400mV (full load) dropout voltages and very low ground current. These devices also find applications in lower current, low dropout-critical systems, where their tiny dropout voltage and ground current values are important attributes.

The LD6362 are fully protected against over current faults, reversed input polarity, and reversed lead insertion, over temperature operation and negative transient voltage spikes.

On the LD6362-Adj the ENABLE pin may be tied to V_{IN} if it is not required for ON/OFF control. The LD6362 are available in 3-pin (fixed version, 3.3V, 5V, others) and 5-pin (adjustable version) TO-220 and surface mount TO-263 packages.

Ordering Information

Part No.	Package	Packing Options	
		Tube (TU)	Tape & Reel (TR)
LD6362	TO220-3	LD6362T3-TU	LD6362T3-TR
	TO220-3	LD6362T4-TU	LD6362T4-TR
	TO263-3	LD6362T7-TU	LD6362T7-TR
	TO263-5	LD6362T9-TU	LD6362T9-TR

- Package material default is “Green” package.

Product Marking

LD8888 SSSSS... 	◇ Line 1 – “LD” is a fixed character 8888: product name ◇ Line 2 – SSSSS...: lot number
---	---

3 Terminal Devices:

Pin 1 =Input, 2 =Ground, 3 =Output

5 Terminal Devices: (adjustable with ON/OFF Control)

Pin 1 =Enable, 2 =Input, 3 =Ground, 4 =Output, 5 =Adjust/Flag

Absolute Maximum Ratings

Parameter	Maximum	Unit
Enable input voltage	20	V
Supply voltage	-20 to +20	V
Operating junction temperature range	-40 to +125	°C
Storage temperature range	-65 to +150	°C
Lead Temperature (Soldering, 5 seconds)	260	°C
Power dissipation	Internally Limited	

The values beyond the boundaries of absolute maximum rating may cause the damage to the device. Functional operation in this context is not implied. Continuous use of the device at the absolute rating level might influence device reliability. All voltages have their reference to device ground.

Electrical Characteristics

$T_J = 25^\circ\text{C}$, unless otherwise noted.

Parameter	Symbol	Condition	Min	Typ.	Max	Unit
Output voltage	V_{OUT}	$I_O=10\text{mA}$	-1	-	1	%
		$10\text{mA} \leq I_O \leq 3\text{A}, (V_{OUT}+1\text{V}) \leq V_{IN} \leq 8\text{V}^{*8}$	-2	-	2	
Line regulation	R_{LINE}	$I_O=10\text{mA}, (V_{OUT}+1\text{V}) \leq V_{IN} \leq 8\text{V}$	-	0.06	0.5	%
Load regulation	R_{LOAD}	$V_{IN}=V_{OUT}+1\text{V}, 10\text{mA} \leq I_{OUT} \leq 3\text{A}$	-	0.2	1	%
Output voltage temperature coefficient ^{*1}	$\Delta V_{OUT}/\Delta T$	-	-	20	100	ppm/°C
Dropout voltage	V_{DO}	$\Delta V_{OUT}=-1\%, I_O=100\text{mA}^{*2*8}$	-	65	200	mV
		$\Delta V_{OUT}=-1\%, I_O=750\text{mA}^{*2}$	-	185	-	
		$\Delta V_{OUT}=-1\%, I_O=1.5\text{A}^{*2*8}$	-	250	-	
		$\Delta V_{OUT}=-1\%, I_O=3\text{A}^{*2*8}$	-	385	550	
Ground current ^{*3}	I_{GND}	$V_{IN}=V_{OUT}+1\text{V}, I_O=750\text{mA}$	-	10	20	mA
		$V_{IN}=V_{OUT}+1\text{V}, I_O=1.5\text{A}$	-	17	-	
		$V_{IN}=V_{OUT}+1\text{V}, I_O=3\text{A}^{*8}$	-	45	-	
Ground pin current at dropout	I_{GNDDO}	$V_{IN}=0.5\text{V}$ less than specified $V_{OUT}, I_{OUT}=10\text{mA}$	-	6	-	mA
Current limit	$I_{OUT}(\text{lim})$	$V_{IN}=V_{OUT}+1\text{V}, V_{OUT}=0\text{V}^{*4*8}$	-	4.5	-	A

ENABLE Input (LD6362-Adj)

Input logic voltage	V_{EN}	Low (OFF) ^{*8}	-	-	0.8	V
		High (ON) ^{*8}	2.5	-	-	
Enable pin input current	I_{EN}	$V_{EN}=2.5\text{V}$	-	15	30	μA
		$V_{EN}=2.5\text{V}^{*8}$	-	-	75	
		$V_{EN}=0.8\text{V}$	-	-	2	
		$V_{EN}=0.8\text{V}^{*8}$	-	-	4	
Regulator output current shutdown ^{*6}	I_{SD}	-	-	10	-	μA
		^{*8}	-	-	20	

Flag Output (Error Comparator) LD6356B/LD6356D

Output leakage current	$I_{FLG}(\text{leak})$	$V_{OH}=16\text{V}$	-	0.01	1.00	μA
		$V_{OH}=16\text{V}^{*11}$	-	-	2.00	
Output low voltage	$V_{FLG}(\text{do})$	Device set for 5V. $V_{IN}=2.5\text{V}, I_{OL}=250\mu\text{A}$	-	220	300	mV
		Device set for 5V. $V_{IN}=2.5\text{V}, I_{OL}=250\mu\text{A}^{*11}$	-	-	400	
Upper threshold voltage	V_{FLG}	Device set for 5V, % of V_{OUT}	-	-	99.2	%
Lower threshold voltage		Device set for 5V, % of V_{OUT}	93	-	-	
Hysteresis		Device set for 5V, % of V_{OUT}	-	1	-	

Reference LD6362-Adj

Reference voltage	V_{REF}	-	1.228	1.210	1.252	V
		^{*8}	1.215	-	1.265	
Adjust pin bias current	I_{ADJ}	-	-	40	80	nA

Notes

1. Exceeding the **ABSOLUTE MAXIMUM RATINGS** may damage the device
2. The device is not guaranteed to function outside its **OPERATING RATING**.
3. Devices are ESD sensitive. The handling precautions are recommended.
4. $V_{DO} = V_{IN} - V_{OUT}$ when V_{OUT} decreases to 99% of its nominal output voltage with $V_{IN} = V_{OUT} + 1V$. For output voltages below 2.5V, the dropout voltage is the input-to-output voltage differential with the minimum input voltage being 2.5V. The minimum input operating voltage is 2.5V.
5. I_{GND} is the quiescent current. $I_{IN} = I_{GND} + I_{OUT}$.
6. $V_{EN} \leq 0.8V$, $V_{IN} \leq 8V$, and $V_{OUT} = 0V$.
7. For 1.8V device, $V_{IN} = 2.5V$.
8. Values are guaranteed across the operating temperature range..

Block Diagram

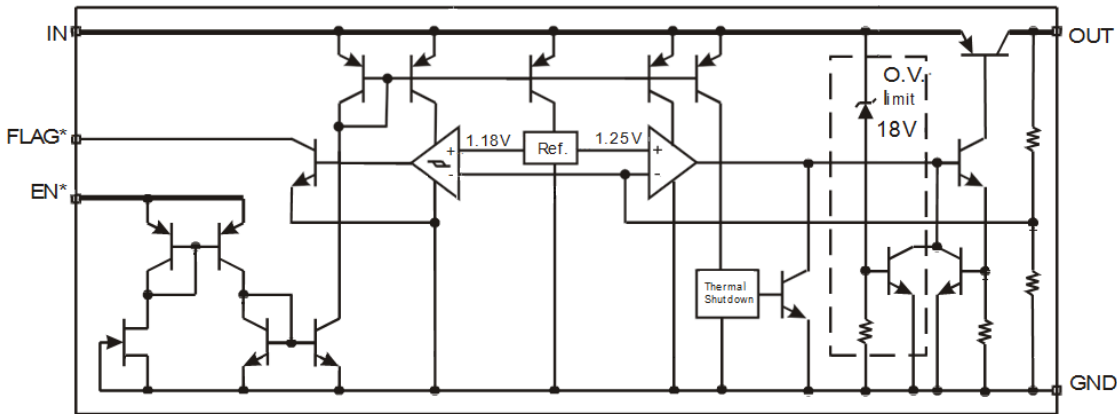

*Feedback network in fixed versions only
 **Adjustable version only

Typical Application Circuit

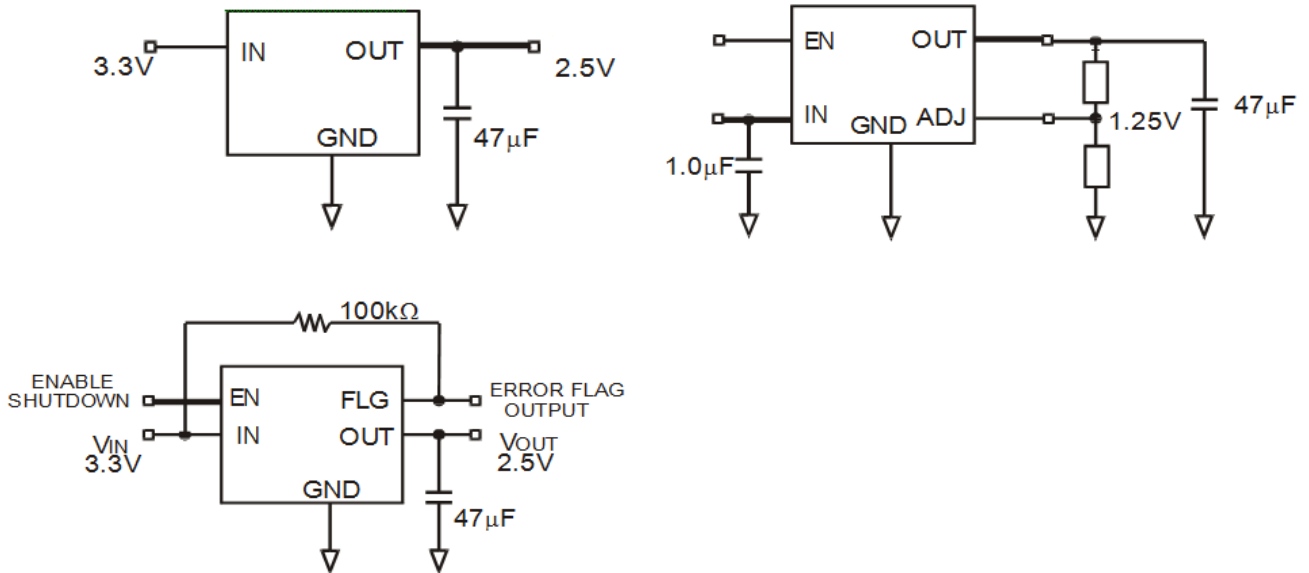

Application Information

ELECTRICAL CHARACTERISTICS

The LD6365 are high performance low-dropout voltage regulators suitable for moderate-to-high current voltage regulator applications. Their 500mV dropout voltage at a full load makes them especially valuable in battery-powered systems and as high-efficiency noise filter in post-regulator applications.

Unlike older NPN-pass transistor designs, where the minimum dropout voltage is limited by the base-to-emitter voltage drop and collector-to-emitter saturation voltage, the dropout performance of the PNP output of these devices is limited only by the low V_{CE} saturation voltage.

A trade-off for the low dropout voltage is a varying base drive requirement. The super-beta PNP process reduces this drive requirement to only 2% to 5% of the load current.

The LD6365 regulators are fully protected from damage due to fault conditions. The current limiting is provided. This limiting is linear; an output current during the overload conditions is constant. The thermal shutdown disables the device when the die temperature exceeds the maximum safe operating temperature. The transient protection allows the device (and load) to survive even when the input voltage spikes above and below the nominal. The output structure of these regulators allows voltages in excess of the desired output voltage to be applied without the reverse current flow.

THERMAL DESIGN

The linear regulators are simple to use. The most complicated design parameters to consider are thermal characteristics. The thermal design requires four application-specific parameters:

- Output current (I_{OUT})
- Output voltage (V_{OUT})
- Input voltage (V_{IN})
- Ground current (I_{GND})

Calculate the regulator power dissipation using these parameters and the device parameter values from this datasheet:

$$P_D = (V_{IN} - V_{OUT}) \cdot I_{OUT} + V_{IN} \cdot I_{GND}$$

The heat sink thermal resistance is determined by:

$$\theta_{SA} = \frac{T_{J(max)} - T_A}{P_D} - (\theta_{JC} + \theta_{CS})$$

where $T_{J(max)} \leq 125^\circ\text{C}$, T_A is the maximum ambient temperature, and θ_{CS} is between 0°C and 2°C/W .

The heat sink may be significantly reduced in applications where the minimum input voltage is known and is large compared with the dropout voltage. Use a series input resistor to drop excessive voltage and distribute the heat between this resistor and the regulator. The low dropout properties of super-beta PNP regulators allow significant reductions in regulator power dissipation and the associated heat sink without compromising the performance. When this technique is employed, a capacitor of at least $1.0\mu\text{F}$ is needed directly between the input and regulator ground.

OUTPUT CAPACITOR

The LD6365 require an output capacitor to maintain stability and improve transient response. Proper selection of the capacitor is important to ensure proper operation. The selection of the output capacitor is dependent upon an equivalent series resistance (ESR) of the output capacitor to maintain the stability. When the output capacitor is $47\mu\text{F}$ or greater, its ESR should be less than 1Ω . This will improve the transient response as well as promote the stability. The ultra-low ESR capacitors, such as ceramic chip capacitors may promote instability. These very low ESR levels may cause an oscillation and/or an under damped

transient response. A low-ESR solid tantalum capacitor works extremely well and provides a good transient response and the stability over the temperature range. Aluminum electrolytic capacitors can also be used, as long as the capacitor ESR is $< 1\Omega$. The output capacitor value can be increased without limit. Higher capacitance values help improving the transient response, ripple rejection, and reducing an output noise.

INPUT CAPACITOR

An input capacitor of $1\mu\text{F}$ or greater is recommended when the device is more than about 10 cm away from the bulk and is used as a supply capacitance, or when the power is battery-supplied. Small, surface-mount, ceramic chip capacitors can be used for the bypassing. Larger values will help improving the ripple rejection by bypassing the input to the regulator, further improving the integrity of the output voltage.

TRANSIENT RESPONSE AND 3.3V TO 2.5V AND 2.5V TO 1.8V CONVERSIONS

The LD6365 have an excellent transient response to variations in the input voltage and load current. The device was designed to respond quickly to load current variations and input voltage variations. Large output capacitors are not required to obtain this performance. A standard $47\mu\text{F}$ output capacitor, preferably tantalum, is all that is required. Larger values help improving the performance even further.

By virtue of its low-dropout voltage, this device does not saturate in the dropout state as readily as similar NPN-based designs.

When converting 3.3V to 2.5V or 2.5V to 1.8V, the NPN-based regulators are already operating in the dropout state, with typical dropout requirements of 1.2V or greater. To convert down to 2.5V without operating in the dropout, NPN-based regulators require an input voltage of 3.7V at the very least.

The LD6365 regulators will provide an excellent performance with an input as low as 3.0V or 2.5V. This gives the PNP-based regulators a distinct advantage over older, NPN-based linear regulators

MINIMUM LOAD CURRENT

The LD6365 regulators are specified to operate in-between finite loads. If the output current is too small, the leakage dominates and the output voltage rises. A 10mA minimum load current is necessary for proper regulation.

ERROR FLAG

The LD6365 version features an error flag circuit which monitors the output voltage and signals an error condition when the voltage drops 5% below the nominal output voltage. The error flag is an open-collector output that can sink 10mA during a fault condition. A low output voltage can be caused by a number of problems, including an over current fault (the device is in the current limit state) or low input voltage. The flag is inoperative during over temperature shutdown.

When the error flag is not used, it is best to leave it open. The FLAG pin can be tied directly to pin 4, the OUT pin.

ENABLE INPUT

The LD6365 versions feature an enable input for on/off control of the device. Its shutdown state draws "zero" current (only microamperes of leakage). The enable input is TTL/CMOS compatible for simple logic interface, but can be connected to up to 20V. When enabled, it draws approximately $15\mu\text{A}$.

Package Outline
TO-220-3:

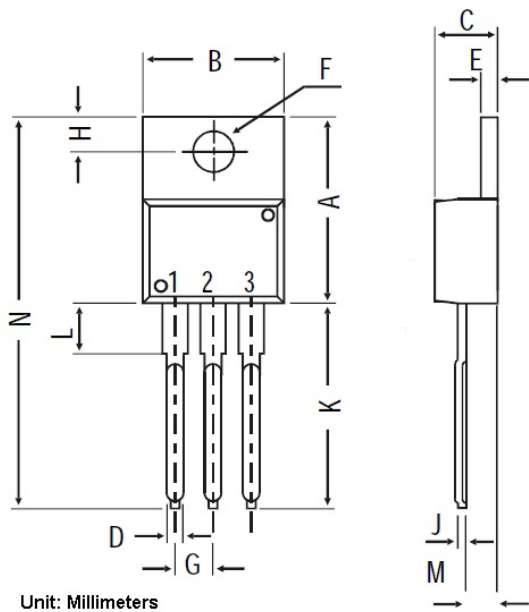

Symbols	Minimum	Normal	Maximum
A	14.42	15.47	16.51
B	9.63	10.15	10.67
C	3.56	4.20	4.83
D	-	0.90	-
E	1.15	1.28	1.4
F	3.75	3.82	3.88
G	2.29	2.54	2.79
H	2.54	2.99	3.43
J	-	0.56	-
K	12.7	13.72	14.73
L	2.8	3.44	4.07
M	2.03	2.48	2.92
N	-	31.24	-

TO-220-5:

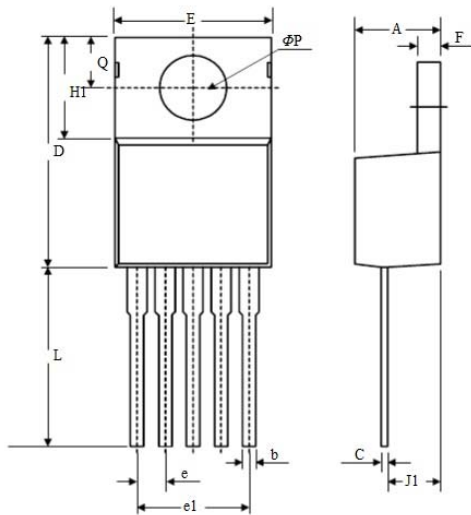

Symbols	Dimensions in Millimeters		
	Minimum	Normal	Maximum
A	4.07	4.45	4.82
b	0.76	0.89	1.02
C	0.36	0.5	0.64
D	14.22	14.86	15.5
E	9.78	10.16	10.54
e	1.57	1.71	1.85
e1	6.68	6.81	6.93
F	1.14	1.27	1.4
H1	5.46	6.16	6.86
J1	2.29	2.74	3.18
L	13.21	13.97	14.73
∅P	3.68	3.81	3.94
Q	2.54	2.73	2.92

Package Outline (Cont')

TO-263-3:

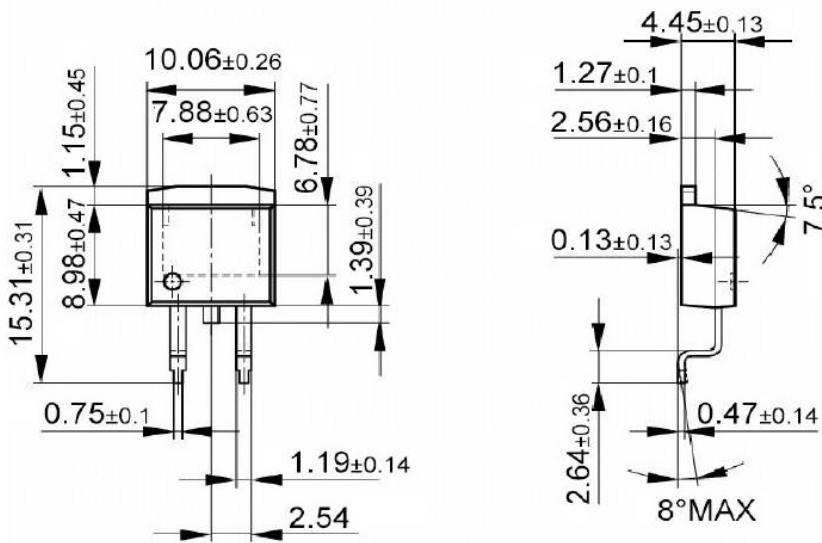

TO-263-5:

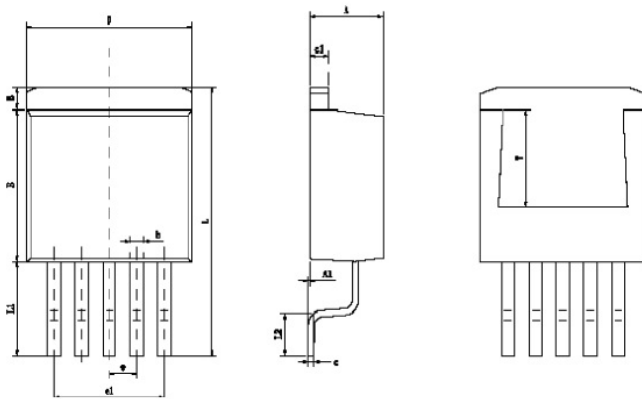

Symbol	Dimensions in Millimeters		Dimensions in Inches	
	Min	Max	Min	Max
A	4.470	4.670	0.176	0.184
A1	0.000	0.150	0.000	0.006
B	1.560	1.760	0.061	0.069
b	0.710	0.910	0.028	0.036
c	0.310	0.530	0.012	0.021
c1	1.170	1.370	0.046	0.054
D	9.880	10.180	0.389	0.401
E	8.200	8.600	0.323	0.339
e	1.700TYP		0.067TYP	
e1	6.700	6.900	0.264	0.272
L	15.140	15.540	0.596	0.612
L1	5.080	5.480	0.200	0.216
L2	2.340	2.740	0.092	0.108

LD Tech Corporation

Tel: +886-3-567-8806
 Fax: +886-3-567-8706
 E-mail: sales@ldtech.com.tw
 Website: www.ldtech.com.tw