

Features

- High current capability: 1.5a
- Low-dropout voltage: 350mv
- Low ground current
- Accurate 1% guaranteed tolerance
- Extremely fast transient response
- Reverse-battery and “load dump” protection
- Zero-current shutdown mode (5-pin versions)
- Error flag signals output out-of-regulation (5-pin versions)
- Also characterized for smaller loads with industry- leading performance specifications
- Fixed voltage and adjustable versions

Applications

- Battery powered equipment
- High-efficiency “green” computer systems
- Automotive electronics
- High-efficiency linear power supplies
- High-efficiency post-regulator for switching supply

Package Pin Out

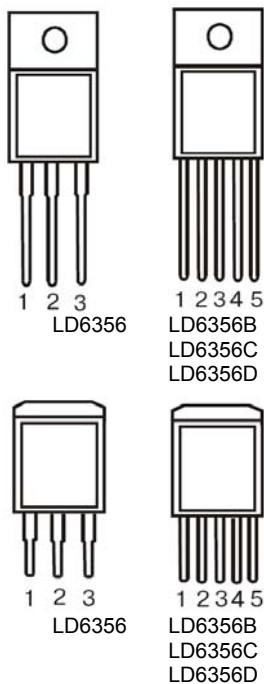

LD6356 Three Terminal Devices:

Pin1 = Input, 2= Ground, 3= Output

LD6356B Five Terminal Fixed Voltage Devices:

Pin1 = Enable, 2= Input, 3= Ground, 4= Output, 5= Flag

LD6356C Adjustable with ON/OFF Control

Pin1= Enable, 2= Input, 3= Ground, 4= Output, 5= Adjust

LD6356D Adjustable with Flag

Pin1= Flag, 2= Input, 3= Ground, 4= Output, 5= Adjust

General Description

The LD6356 are high current, high accuracy, low-dropout voltage regulators. Using process with a PNP pass element, these regulators feature 350mV (full load) dropout voltages and very low ground current. These devices also find applications in lower current, low drop-out-critical systems, where their tiny dropout voltage and ground current values are important attributes.

The LD6356 are fully protected against over current faults, reversed input polarity, reversed lead insertion, over temperature operation, and positive and negative transient voltage spikes. Five pin fixed voltage versions feature logic level ON/OFF control and an error flag which signals whenever the output falls out of regulation.

On the MIC29151 and MIC29152, the ENABLE pin maybe tied to V_{IN} if it is not required for ON/OFF control. The LD6356 are available in 3 and 5 pin TO-220 and surface mount TO-263 packages.

Ordering Information

Part No.	Package	Packing Options	
		Tube (TU)	Tape & Reel (TR)
LD6356	TO220	LD6356T4-TU	LD6356T4-TR
	TO263	LD6356T9-TU	LD6356T9-TR

- Package material default is “Green” package.

Product Marking

LD8888
SSSSS...

- ◇ Line 1 – “LD” is a fixed character
8888: product name
- ◇ Line 2 – SSSSS...: lot number

Absolute Maximum Ratings

Parameter	Maximum	Unit
Input Supply Voltage (Note 1)	-20 to +60	V
Maximum Operating Input Voltage	26	V
Operating Junction Temperature	-40 to +125	°C
Storage Temperature Range	-65 to +150	°C
Lead Temperature (Soldering, 5 seconds)	260	°C
Power Dissipation	Internally Limited	

The values beyond the boundaries of absolute maximum rating may cause the damage to the device. Functional operation in this context is not implied. Continuous use of the device at the absolute rating level might influence device reliability. All voltages have their reference to device ground.

Electrical Characteristics

All measurements at $T_J = 25^\circ\text{C}$ unless otherwise noted. **Bold** values are guaranteed across the operating temperature range. Adjustable versions are programmed to 5.0V.

Parameter	Symbol	Condition	Min	Typ.	Max	Unit
Input						
Output voltage	V_{OUT}	$I_O=10\text{mA}$	-1	-	1	%
		$10\text{mA} \leq I_O \leq I_{FL}, (V_{OUT}+1\text{V}) \leq V_{IN} \leq 26\text{V}^{*2*11}$	-2	-	2	
Line regulation	R_{LINE}	$I_O=10\text{mA}, (V_{OUT}+1\text{V}) \leq V_{IN} \leq 26\text{V}$	-	0.06	0.5	%
Load regulation ^{*2*6}	R_{LOAD}	$V_{IN}=V_{OUT}+5\text{V}, 10\text{mA} \leq I_{OUT} \leq I_{FULLLOAD}$	-	0.2	1	%
Output voltage temperature coefficient	$\Delta V_{OUT}/\Delta T$	^{*6}	-	20	100	ppm/°C
Dropout voltage ^{*3}	V_{DO}	$\Delta V_{OUT}=-1\%, I_O=100\text{mA}$	-	80	200	mV
		$\Delta V_{OUT}=-1\%, I_O=750\text{mA}$	-	220	-	
		$\Delta V_{OUT}=-1\%, I_O=1.5\text{A}$	-	350	600	
Ground current	I_{GND}	$I_O=750\text{mA}, V_{IN}=V_{OUT}+1\text{V}$	-	8	20	mA
		$I_O=1.5\text{A}$	-	22	-	
Ground pin current at dropout	I_{GNDDO}	$V_{IN}=0.5\text{V}$ less than specified $V_{OUT}, I_{OUT}=10\text{mA}$	-	2	-	mA
Current limit ^{*4}	$I_{OUT}(\text{lim})$	LD6356 $V_{OUT}=0\text{V}$	-	2.1	3.5	A
Output noise voltage (10Hz to 100kHz)	V_{NOISE}	$I_L=100\text{mA}, C_L=10\mu\text{F}$	-	400	-	μVRMS
		$I_L=100\text{mA}, C_L=33\mu\text{F}$	-	260	-	
Reference LD6356C						
Reference voltage	V_{REF}		1.228	1.240	1.252	V
		^{*11}	1.215	-	1.265	
		^{*8*11}	1.20	-	1.277	
Adjust pin current	$I_{ADJBias}$		40	-	80	nA
		^{*11}	-	-	120	
Reference voltage temperature coefficient	$\Delta V_{REF}/\Delta T$	^{*7}	-	20	-	ppm/°C
Adjust pin bias current temperature coefficient	$\Delta I_{ADJ}/\Delta T$		-	0.1	-	nA/°C
Flag Output (Error Comparator) LD6356B/LD6356D						
Output leakage current	$I_{FLG}(\text{leak})$	$V_{OH}=26\text{V}$	-	0.001	1.00	μA
		$V_{OH}=26\text{V}^{*11}$	-	-	2.00	
Output low voltage	$V_{FLG}(\text{do})$	Device set for 5V. $V_{IN}=4.5\text{V}, I_{OL}=250\mu\text{A}$	-	220	300	mV
		Device set for 5V. $V_{IN}=4.5\text{V}, I_{OL}=250\mu\text{A}^{*11}$	-	-	400	
Upper threshold voltage	V_{FLG}	Device set for 5V, % of V_{OUT}	-	-	99.2	%
Lower threshold voltage		Device set for 5V, % of V_{OUT}	93	-	-	
Hysteresis		Device set for 5V, % of V_{OUT}	-	1	-	

ENABLE Input LD6356B/LD6356C						
Input logic voltage	V _{EN}	Low (off) ^{*11}	–	–	0.8	V
		High (on) ^{*11}	2.4	–	–	
Enable pin input current	I _{EN}	VEN=26V	–	100	600	μA
		VEN=26V ^{*11}	–	–	750	
		VEN=0.8V	–	–	2.5	
		VEN=0.8V ^{*11}	–	–	5	
Regulator output current shutdown ^{*9}	I _{SD}		–	10	–	μA
		^{*11}	–	–	500	

Notes:

1. Maximum positive supply voltage of 60V must be of limited duration (<100msec) and duty cycle (≤1%). The maximum continuous supply voltage is 26V.
2. Full Load current (IFL) is defined as 1.5A.
3. Dropout voltage is defined as the input-to-output differential when the output voltage drops to 99% of its nominal value with V_{OUT} to VIN
4. VIN = V_{OUT} (nominal) + 1V. For example, use VIN = 4.3V for a 3.3V regulator or use 6V for a 5V regulator. Employ pulse-testing procedures to minimize temperature rise.
5. Ground pin current is the regulator quiescent current. The total current drawn from the source is the sum of the load current plus the ground pin current.
6. Output voltage temperature coefficient is defined as the worst case voltage change divided by the total temperature range.
7. Thermal regulation is defined as the change in output voltage at a time T after a change in power dissipation is applied, excluding load or line regulation effects. Specifications are for a 200mA load pulse at VIN = 20V (a 4W pulse) for T = 10ms.
8. VREF ≤ V_{OUT} ≤ (VIN-1V), 2.3V ≤ VIN ≤ 26V, 10mA < I_L IFL, T_J < T_J MAX.
9. VEN ≤ 0.8V and VIN ≤ 26V, V_{OUT}=0
10. When used in dual supply systems where the regulator load is returned to a negative supply, the output voltage must be diode clamped to ground.
11. Values are guaranteed across the operating temperature range.

Block Diagram

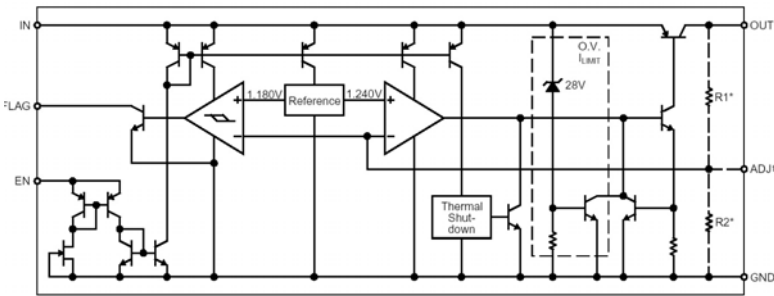

*Feedback network in fixed versions only
 **Adjustable version only

Typical Application Circuit

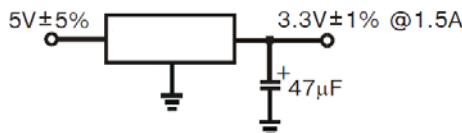

Figure1. Fixed output voltage

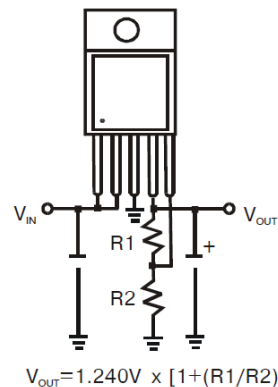

Figure2. Adjustable output voltage configuration. For best results, the total series resistance should be small enough to pass the minimum regulator load current

Applications Information

The LD6356 are high performance low-dropout voltage regulators suitable for all moderate to high current voltage regulator applications. Their 350mV dropout voltage at full load make them especially valuable in battery powered systems and as high efficiency noise filters in “post-regulator” applications.

Unlike older NPN-pass transistor designs, dropout performance of the PNP output of these devices is limited merely by the low VCE saturation voltage.

The LD6356 family of regulators is fully protected from damage due to fault conditions. Current limiting is provided. This limiting is linear; output current under overload conditions is constant. Thermal shutdown disables the device when the die temperature exceeds the 125°C maximum safe operating temperature.

Transient protection allows device survival even when the input voltage spikes between -20V and +60V.

When the input voltage exceeds about 35V to 40V, the over voltage sensor temporarily disables the regulator.

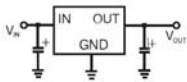

Figure 3. Linear regulators require only two capacitors for operation.

Thermal Design

Linear regulators are simple to use. The most complicated design parameters to consider are thermal characteristics. Thermal design requires the following application-specific parameters:

- Maximum ambient temperature, T_A
- Output Current, I_{OUT}
- Output Voltage, V_{OUT}
- Input Voltage, V_{IN}

First, we calculate the power dissipation of the regulator from these numbers and the device parameters from this data-sheet.

$$P_D = I_{OUT}(1.01V_{IN} - V_{OUT})$$

Where the ground current is approximated by 1% of I_{OUT} .

Then the heat sink thermal resistance is determined with this formula:

$$\theta_{SA} = \frac{T_{JMAX} - T_A}{P_D} - (\theta_{JC} + \theta_{CS})$$

Where $T_{JMAX} \leq 125^\circ C$ and θ_{CS} is between 0 and 20C/W.

Capacitor Requirements

For stability and minimum output noise, a capacitor on the regulator output is necessary. The value of this capacitor is dependent upon the output current; lower currents allow smaller capacitors. LD6356 regulators are stable with the 10 μF minimum capacitor values at full load.

Where the regulator is powered from a source with a high AC impedance, a 0.1 μF capacitor connected between Input and GND is recommended. This capacitor should have good characteristics to above 250kHz.

Minimum Load Current

The LD6356 regulators are specified between finite loads. If the output current is too small, leakage currents dominate and the output voltage rises. The 5mA minimum load current swamps any expected leakage current across the operating temperature range.

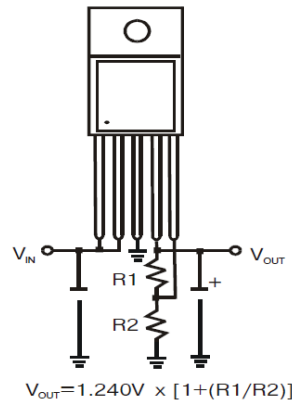

Adjustable Regulator Design

Figure 4. Adjustable Regulator with Resistors The adjustable regulator versions, LD6356C and LD6356D, allow programming the output voltage anywhere between 1.25V and the 26V maximum operating rating of the family Two resistors are used. Resistors can be quite large, up to 1M Ω , because of the very high input impedance and low bias current of the sense comparator: The resistor values are calculated by:

$$R_1 = R_2 \left(\frac{V_{OUT}}{1.240} - 1 \right)$$

Where is V_O the desired output voltage. Figure 4 shows component definition. Applications with widely varying load currents may scale the resistors to draw the minimum load current required for proper operation.

Error Flag

LD6356B and LD6356D versions feature an Error Flag, which looks at the output voltage and signals an error condition when this voltage drops 5% below its expected value. The error flag is an open-collector output that pulls low under fault conditions. It may sink 10mA. Low output voltage signifies a number of possible problems, including an over-current fault (the device is in current limit) and low input voltage. The flag output is inoperative during over temperature shutdown conditions.

Enable Input

LD6356B and LD6356C versions feature an enable (EN) input that allows ON/OFF control of the device. Special design allows “zero” current drain when the device is disabled-only microamperes of leakage current flows. The EN input has TTL/CMOS compatible thresholds for simple interfacing with logic, or may be directly tied to $\leq 30V$. Enabling the regulator requires approximately 20 μA of current.

Package Outline
TO-220-3:

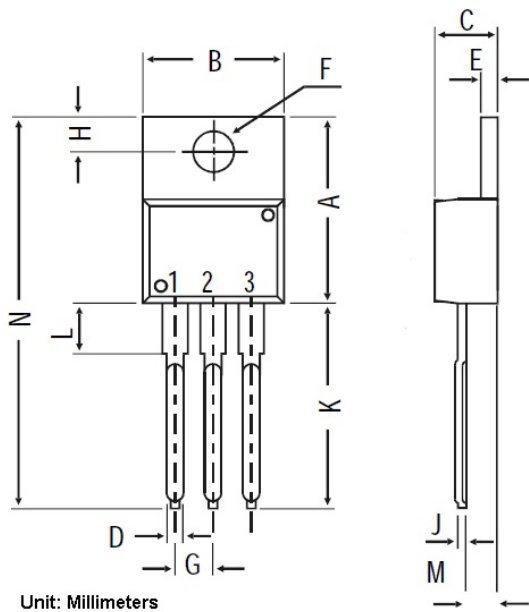

Symbols	Minimum	Normal	Maximum
A	14.42	15.47	16.51
B	9.63	10.15	10.67
C	3.56	4.20	4.83
D	-	0.90	-
E	1.15	1.28	1.4
F	3.75	3.82	3.88
G	2.29	2.54	2.79
H	2.54	2.99	3.43
J	-	0.56	-
K	12.7	13.72	14.73
L	2.8	3.44	4.07
M	2.03	2.48	2.92
N	-	31.24	-

Unit: Millimeters

TO-220-5:

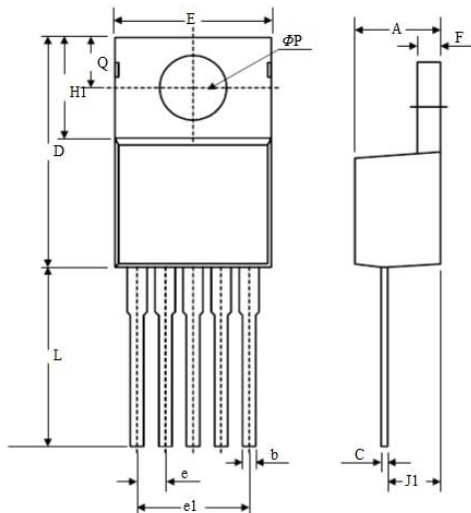

Symbols	Dimensions in Millimeters		
	Minimum	Normal	Maximum
A	4.07	4.45	4.82
b	0.76	0.89	1.02
C	0.36	0.5	0.64
D	14.22	14.86	15.5
E	9.78	10.16	10.54
e	1.57	1.71	1.85
e1	6.68	6.81	6.93
F	1.14	1.27	1.4
H1	5.46	6.16	6.86
J1	2.29	2.74	3.18
L	13.21	13.97	14.73
∅P	3.68	3.81	3.94
Q	2.54	2.73	2.92

Package Outline (Cont')

TO-263-3:

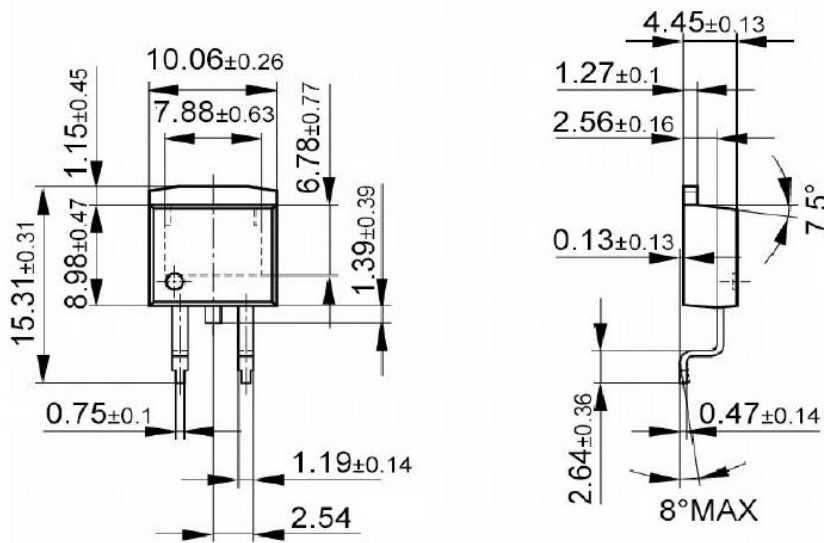

TO-263-5:

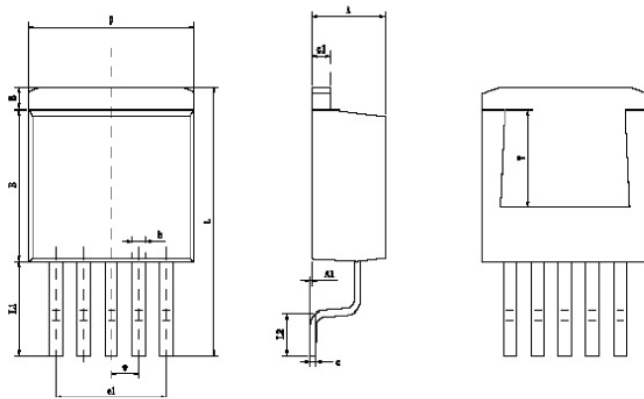

Symbol	Dimensions in Millimeters		Dimensions in Inches	
	Min	Max	Min	Max
A	4.470	4.670	0.176	0.184
A1	0.000	0.150	0.000	0.006
B	1.560	1.760	0.061	0.069
b	0.710	0.910	0.028	0.036
c	0.310	0.530	0.012	0.021
c1	1.170	1.370	0.046	0.054
D	9.880	10.180	0.389	0.401
E	8.200	8.600	0.323	0.339
e	1.700TYP		0.067TYP	
e1	6.700	6.900	0.264	0.272
L	15.140	15.540	0.596	0.612
L1	5.080	5.480	0.200	0.216
L2	2.340	2.740	0.092	0.108

LD Tech Corporation

Tel: +886-3-567-8806
 Fax: +886-3-567-8706
 E-mail: sales@ldtech.com.tw
 Website: www.ldtech.com.tw