

Features

- Adjustable or fixed output
- Output current of 1.5A
- Low dropout, 1.5V typ. at 1.5A output current
- 0.04% line regulation
- 0.2 % load regulation
- 100% thermal limit burn-in
- Fast transient response

Applications

- High efficiency linear regulators
- Post regulators for switching supplies
- Adjustable power supply

Package Pin Out

SOT-223



TO-252

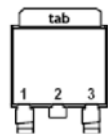

PIN	FUNCTION
1	ADJ/GND
2	OUTPUT
3	INPUT

General Description

The LD6355 series of positive adjustable and fixed regulators is designed to provide 1.5A with high efficiency. All the internal circuitry is designed to operate down to 1.4V input-to-output differential. On-chip trimming adjusts the reference voltage to 1%.

Ordering Information

Part No.	Package	Packing Options	
		Tube (TU)	Tape & Reel (TR)
LD6355	SOT223	LD6355-vvL8-TU	LD6355-vv L8-TR
	TO252	LD6355-vv T6-TU	LD6355-vv T6-TR

- Package material default is "Green" package.

Product Marking

LD8888
SSSSS...

- ◇ Line 1 – "LD" is a fixed character
8888: product name
- ◇ Line 2 – SSSSS...: lot number



Absolute Maximum Ratings

Parameter	Maximum	Unit
Power dissipation	Internally limited	W
Input voltage	15	V
Operating junction temperature (Control section)	0 to 125	°C
Operating junction temperature (Power transistor)	0 to 150	°C
Storage temperature	-65 to 150	°C
Lead temperature (soldering, 10 sec)	300	°C

The values beyond the boundaries of absolute maximum rating may cause the damage to the device. Functional operation in this context is not implied. Continuous use of the device at the absolute rating level might influence device reliability. All voltages have their reference to device ground.

Electrical Characteristics

$I_{LOAD} = 0\text{mA}$ and $T_J = 25^\circ\text{C}$ unless specified, otherwise minimum and maximum values are guaranteed by production testing requirements.

Parameter	Symbol	Condition	Min	Typ.	Max	Unit
Reference voltage ^{*2}	V_{REF}	$V_{IN} = 5\text{V}, I_{LOAD} = 10\text{mA}$ ^{*6}	1.238	1.250	1.262	V
		$1.5\text{V} \leq V_{IN} - V_{OUT} \leq 10\text{V}, I_{LOAD} = 10\text{mA to } 1.5\text{A}$, ^{**16}	1.225	1.250	1.275	V
Accuracy of output voltage ^{*2}	$A_{CCVOUTF}$	$V_{IN} = V_{OUT} + 1.5\text{V}$, Varied from nominal V_{OUT} ^{*5}	-1	-	+1	%
		$1.5\text{V} \leq V_{IN} - V_{OUT} \leq 10\text{V}, I_{LOAD} = 0\text{mA to } 1.5\text{A}$, ^{**15}	-2	-	+2	%
Line regulation ^{*2}	R_{LINE}	$I_{LOAD} = 10\text{mA}, 1.5\text{V} \leq V_{IN} - V_{OUT} \leq 10\text{V}$, ^{*1}	-	0.04	0.20	%
Load regulation ^{*2}	R_{LOAD}	$V_{IN} = V_{OUT} + 1.5\text{V}, I_{LOAD} = 10\text{mA to } 1.5\text{A}$, ^{*1}	-	0.2	0.40	%
Minimum load current	I_{LOAD}	$V_{IN} = 5\text{V}, V_{ADJ} = 0\text{V}$, ^{**16}	-	3	7	mA
GND pin current	I_{GND}	$V_{IN} = V_{OUT} + 1.5\text{V}, I_{LOAD} = 10\text{mA to } 1.5\text{A}$, ^{**15}	-	7	10	mA
ADJ pin current	I_{ADJ}	$1.5\text{V} \leq V_{IN} - V_{OUT} \leq 10\text{V}, I_{LOAD} = 10\text{mA}$, ^{**16}	-	10	90	μA
Current limit	I_{LIMIT}	$V_{IN} - V_{OUT} = 1.5\text{V}$, ^{*1}	1.5	2.2	-	A
Ripple rejection ^{*3}	R_{RIPPLE}	$V_{IN} - V_{OUT} = 3.0\text{V}, I_{LOAD} = 1.5\text{A}$ ^{*1}	60	65	-	dB
Dropout voltage ^{**24}	V_{DROPUT}	$I_{LOAD} = 1.5\text{A}$, ^{*1}	-	1.30	1.50	V
Temperature coefficient	T_{COEF}	$V_{IN} - V_{OUT} = 1.5\text{V}, I_{LOAD} = 10\text{mA}$, ^{*1}	-	0.005	-	%/°C

1. Denotes "apply over the full temperature range" $0^\circ\text{C} \leq T_J \leq 125^\circ\text{C}$
2. Low duty pulse testing with Kelvin connections is required
3. 120Hz input ripple ($C_{ADJ} = 25\mu\text{F}$, $C_{OUT} = 25\mu\text{F}$ for the Adj version)
4. $V_{OUT}, V_{REF} = 1\%$
5. V_{OUT} output fixed version only
6. V_{OUT} adjustable version only

Block Diagram

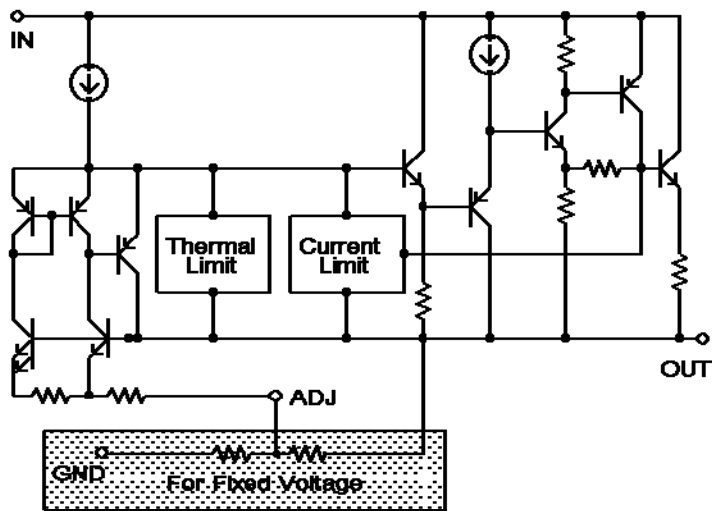

Typical Application Circuit and OTP Function Chart

Fixed Voltage Regulator

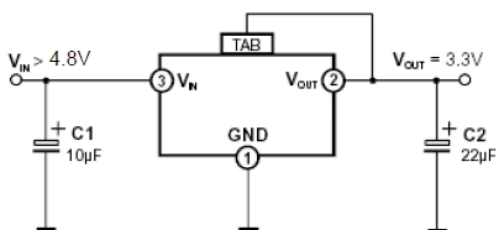

NOTES:

- $C1$ needed if device is far from filter capacitors
- $C2$ minimum value required for stability

Adjustable Voltage Regulator

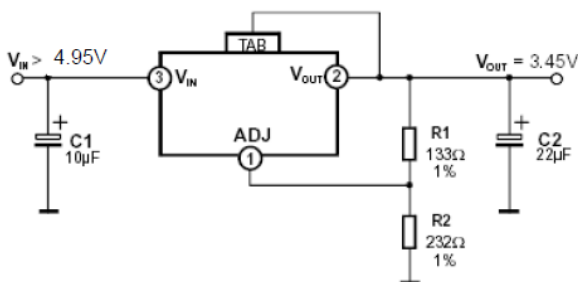

$$V_{OUT} = V_{REF} \times \left(1 + \frac{R2}{R1}\right) + I_{ADJ} \times R2$$

APPLICATION INFORMATION

The LD6355 series of adjustable and fixed regulators are easy to use and have all the protection features expected in high performance voltage regulators: short circuit protection and thermal shut-down.

Pin compatible with older three terminal adjustable regulators, these devices offer the advantage of a lower dropout voltage, more precise reference tolerance and improved reference stability with temperature.

STABILITY

The circuit design used in the LD6355 series requires the use of an output capacitor as part of the device frequency compensation.

The addition of 150µF aluminum electrolytic or a 22µF solid tantalum on the output will ensure stability for all operating conditions.

When the adjustment terminal is bypassed with a capacitor to improve the ripple rejection, the requirement for an output capacitor increases. The value of 22µF tantalum or 150µF aluminum covers all cases of bypassing the adjustment terminal. Without bypassing the adjustment terminal smaller

capacitors can be used with equally good results.

To ensure good transient response with heavy load current changes capacitor values on the order of 100µF are used in the output of many regulators. To further improve stability and transient response of these devices larger values of output capacitor can be used.

PROTECTION DIODES

Unlike older regulators, the LD6355 family does not need any protection diodes between the adjustment pin and the output and from the output to the input to prevent over-stressing the die.

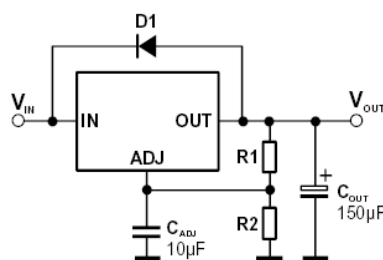

Internal resistors are limiting the internal current paths on the LD6355 adjustment pin, therefore even with capacitors on the adjustment pin no protection diode is needed to ensure device safety under short-circuit conditions.

Diodes between the input and output are not usually needed. Microsecond surge currents of 50A to 100A can be handled by the internal diode between the input and output pins of the device. In normal operations it is difficult to get those values of surge currents even with the use of large output capacitances. If high value output capacitors are used, such as 1000µF to 5000µF and the input pin is instantaneously shorted to ground, damage can occur. A diode from output to input is recommended, when a crowbar circuit at the input of the LD6355 is used. Normal power supply cycling or even plugging and unplugging in the system will not generate current large enough to do any damage.

The adjustment pin can be driven on a transient basis ±25V, with respect to the output without any device degradation. As with any IC regulator, none the protection circuitry will be functional and the internal transistors will break down if the maximum input to output voltage differential is exceeded.

RIPPLE REJECTION

The ripple rejection values are measured with the adjustment pin bypassed. The impedance of the adjust pin capacitor at the ripple frequency should be less than the value of R1 (normally 100Ω to 120Ω) for a proper bypassing and ripple rejection approaching the values shown. The size of the required adjust pin capacitor of the input ripple frequency. If R1=100Ω at 120Hz the adjust pin capacitor should be 25µF. At 10KHz only 0.22µF is needed.

The ripple rejection will be a function of output voltage, in circuits without an adjust pin bypass capacitor. The output ripple will increase directly as a ratio of the output voltage to the reference voltage (V_{OUT} / V_{REF}).

OUTPUT VOLTAGE

The LD6355 series develops a 1.25V reference voltage between the output and the adjust terminal.

Placing a resistor between these two terminals causes a constant current to flow through R1 and down through R2 to set the overall output voltage.

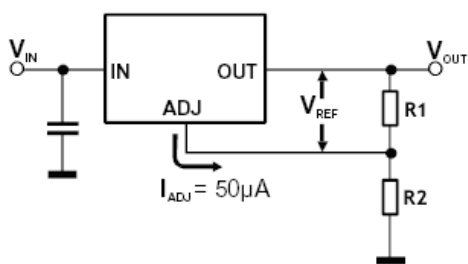

This current is normally the specified minimum load current of 7mA. Because I_{ADJ} is very small and constant it represents a small error and it can usually be ignored.

LOAD REGULATION

True remote load sensing it is not possible to provide, because the LD6355 is a three terminal device. The resistance of the wire connecting the regulator to the load will limit the load regulation.

The data sheet specification for load regulation is measured at the bottom of the package. Negative side sensing is a true Kelvin connection, with the bottom of the output divider returned to the negative side of the load.

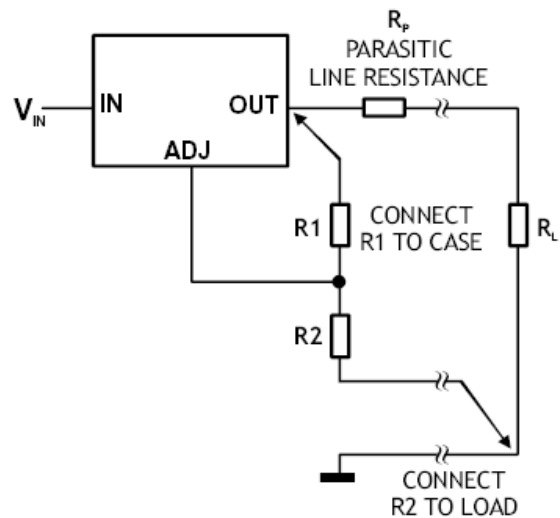

The best load regulation is obtained when the top of the resistor divider R1 is connected directly to the case not to the load. If R1 were connected to the load, the effective resistance between the regulator and the load would be:

$$\frac{R_p \times (R_2 + R_1)}{R_1}, \text{ } R_p = \text{Parasitic Line Resistance}$$

Connected as shown above, R_p is not multiplied by the divider ratio. Using 16-gauge wire the parasitic line resistance is about 0.004Ω per foot, translating to 4mV/ft at 1A load current. It is important to keep the positive lead between regulator and load as short as possible and use large wire or PC board traces.

THERMAL CONSIDERATIONS

The LD6355 series have internal power and thermal limiting circuitry designed to protect the device under overload conditions. However maximum junction temperature ratings should not be exceeded under continuous normal load conditions.

Careful consideration must be given to all sources of thermal resistance from junction to ambient, including junction-to-case, case-to-heat sink interface and heat sink resistance itself. To ensure safe operating temperatures and reflect more accurately the device temperature, new thermal resistance specifications have been developed.

Unlike older regulators with a single junction-to-case thermal resistance specification, the data section for these new regulators provides a separate thermal resistance and maximum junction temperature for both the Control Section and the Power Transistor.

Calculations for both temperatures under certain conditions of ambient temperature and heat sink resistance and to ensure that both thermal limits are met.

Junction-to-case thermal resistance is specified from the IC junction to the bottom of the case directly below the die. This is the lowest resistance path for the heat flow. In order to ensure the best possible thermal flow from this area of the package to the heat sink proper mounting is required.

Thermal compound at the case-to-heat sink interface is recommended. A thermally conductive spacer can be used, if the case of the device must be electrically isolated, but its added contribution to thermal resistance has to be considered.

Package Outline

TO-252:

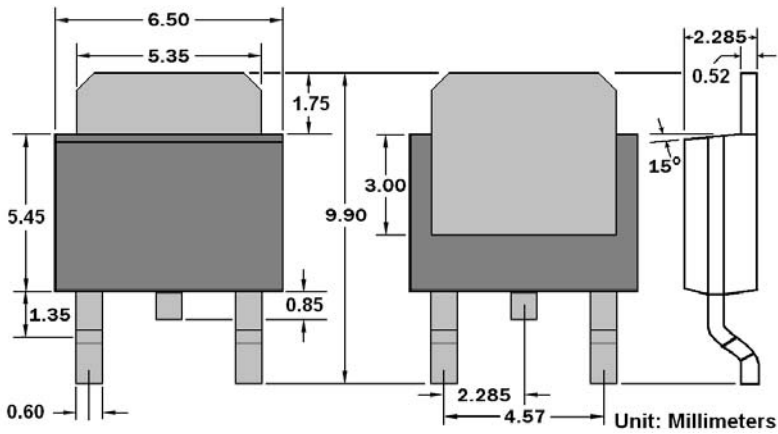

SOT-223:

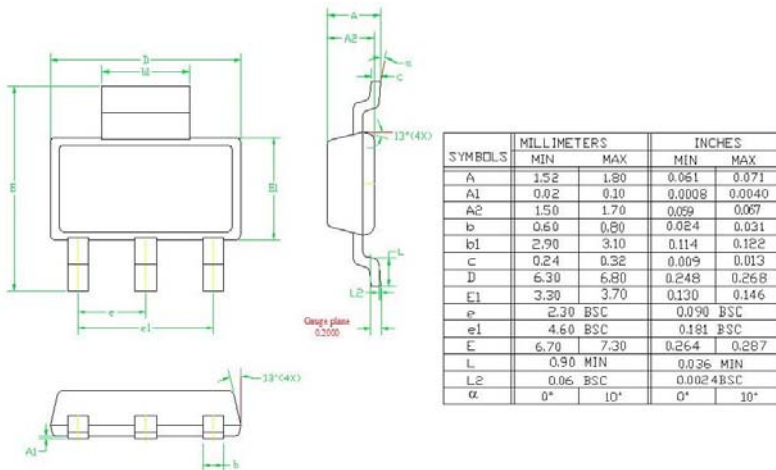

LD Tech Corporation

Tel: +886-3-567-8806
Fax: +886-3-567-8706
E-mail: sales@ldtech.com.tw
Website: www.ldtech.com.tw